

SERIES 4500
TWIN DOUBLE HUNG WINDOW – BALANCE – "IMPACT"
BY OWW LLC

DESIGN PRESSURE = +47, -50

GENERAL NOTES

1. This product has been evaluated and is in compliance with 8th Edition (2023) Florida Building Code (FBC) structural requirements including the "High Velocity Hurricane Zone" (HVHZ).
2. Product anchors shall be as listed and spaced as shown on details. Anchor embedment to base materials shall be beyond wall dressing or stucco. All anchors used shall be of a material or have a coating compatible with pressure treated wood if used, and all other window materials.
3. When used in the "HVHZ" this product complies with Section 1626 of the FBC and does not require an impact resistant covering.
4. The opening substrate materials (framing, masonry, bucks) are by others and must be properly designed and installed to transfer superimposed loads to the structure. For 2X stud framing construction, anchoring of these units shall be the same as that shown for 2X buck masonry construction. Wood bucks over masonry, if used, shall be pressure treated, with either a treatment or coating compatible with this product and anchors.
5. All window frame wood to be Specific Gravity of 0.55 min. (Sapele or similar).
6. Site conditions that deviate from the details of this drawing require further engineering analysis by a licensed engineer or registered architect.
7. This product has been laboratory tested to meet the water infiltration requirements for "HVHZ." Sealing and flashing strategies for overall water infiltration resistance of the field-installed product shall be the responsibility of others and are not addressed by this document.

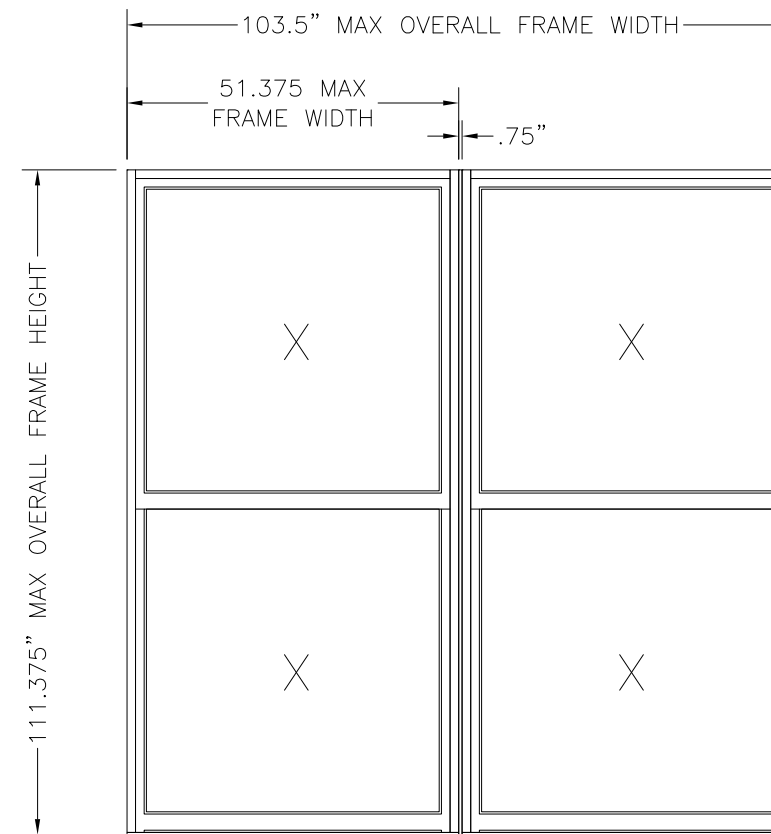

TABLE OF CONTENTS

SHEET #	DESCRIPTION
1	Typical elevation, design pressures & general notes
2	Horizontal cross sections
3	Horizontal cross sections
4	Vertical cross sections
5	Frame details
6	Buck and frame anchoring
7	Components
8	Bill of materials, components & glazing details

TABLE 1. QUALIFIED ANCHOR INFORMATION

ID	SUBSTRATE	ANCHOR	MIN. EMBEDMENT	MIN. EDGE DISTANCE
A	SOLID UNCRACKED CONCRETE (3050 PSI MIN.)	1/4" DEWALT COATED CARBON STEEL ULTRACON+	1 3/8"	1"
B	GROUT-FILLED CMU (ASTM C-90) (JAMBS ONLY)	1/4" DEWALT COATED CARBON STEEL ULTRACON+	1 3/4"	2 1/2"
C	SOLID UNCRACKED CONCRETE (2000 PSI MIN.)	1/4" ITW COATED CARBON STEEL TAPCON W/ ADVANCED THREADFORM	1 1/2"	1 1/2"
D	HOLLOW CMU (117 PCF MIN.) (JAMBS ONLY)	1/4" ITW COATED CARBON STEEL TAPCON W/ ADVANCED THREADFORM	1"	2"
E	CONCRETE (3000 PSI MIN)	1/4" HILTI COATED CARBON STEEL KWIK-CON+	1"	2 1/2"
F	HOLLOW OR GROUT-FILLED CMU (ASTM C-90) (JAMBS ONLY)	1/4" HILTI COATED CARBON STEEL KWIK-CON+	1"	2 1/2"
G	2x MIN. SOUTHERN PINE WOOD (G=0.55 MIN)	#12 GRADE 5 WOOD SCREW	1 1/2"	1"
H	16 GAUGE (0.060") MIN. STEEL STUD (33 KSI YIELD MIN.) OR 1/8" MIN. ALUMINUM (6063-T5 MIN.)	#14 ITW TEKS SELF-DRILLING SCREW	FULL + 3 THREADS	1/2"

OVERALL FRAME DIMENSION	OVERALL D.L.O DIMENSION	GLASS TYPE	DESIGN PRESSURE (PSF)	
			POSITIVE	NEGATIVE
103.5" X 111.375"	43.0" X 50.5"	G1, G2	+ 47.0	- 50.0

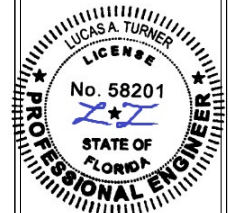

10/18/2023

TE&C
LUCAS A. TURNER, P.E. FL PE 58201
TURNER ENGINEERING & CONSULTING, INC.
PH. 941-380-1574
2428 OLD NACHEZ TRACE TRAIL
CAMDEN, TN 38320

OWW LLC
3001 Tuvedo Ave., West Palm Beach, FL 33405
Ph. 561-478-7233 Fax 561-478-7858

Product: SERIES 4500 TWIN DOUBLE HUNG BALANCE WINDOW
Date: 05-07-14
Scale: None
Drawn: JDS
TYPICAL ELEVATION, DESIGN PRESSURES & GENERAL NOTES

Dwg. DH-TwinBal
FL34941.5

Sheet No.
1D OF 8

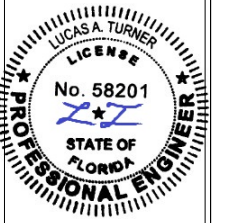
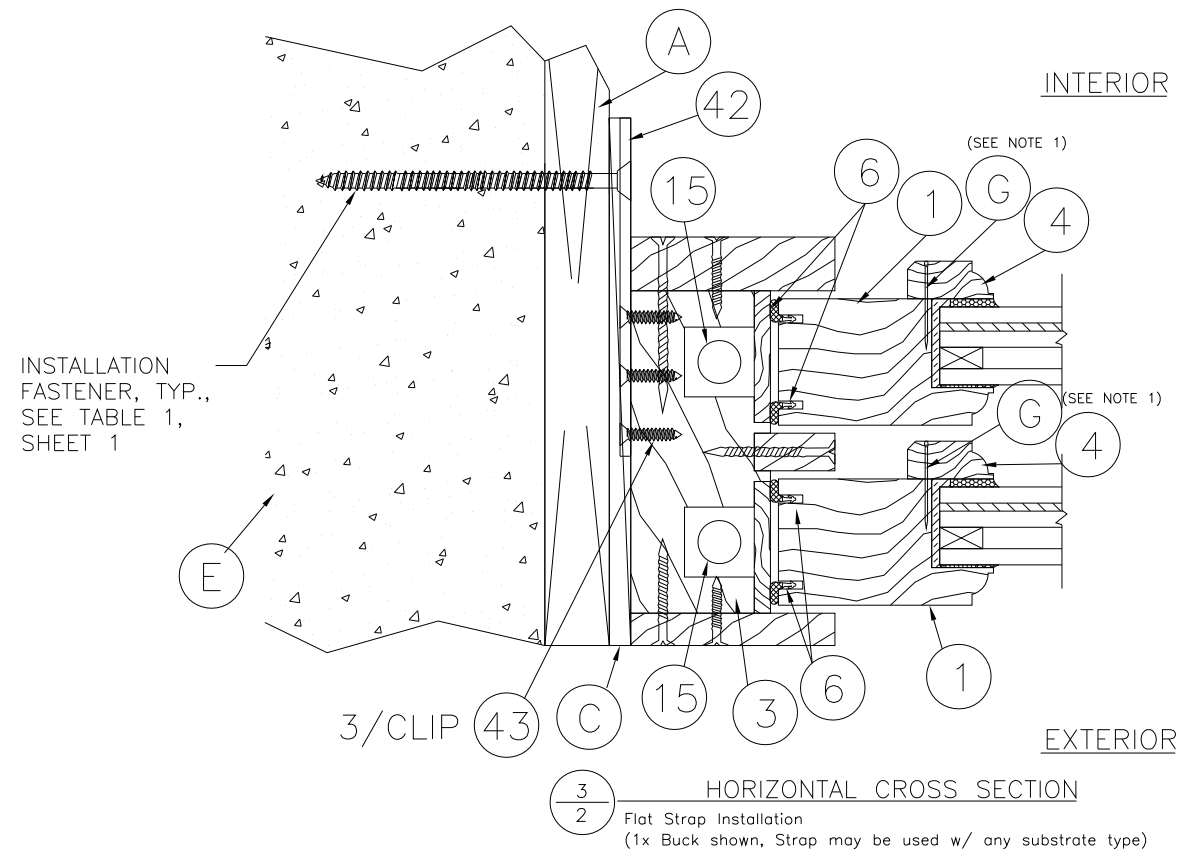
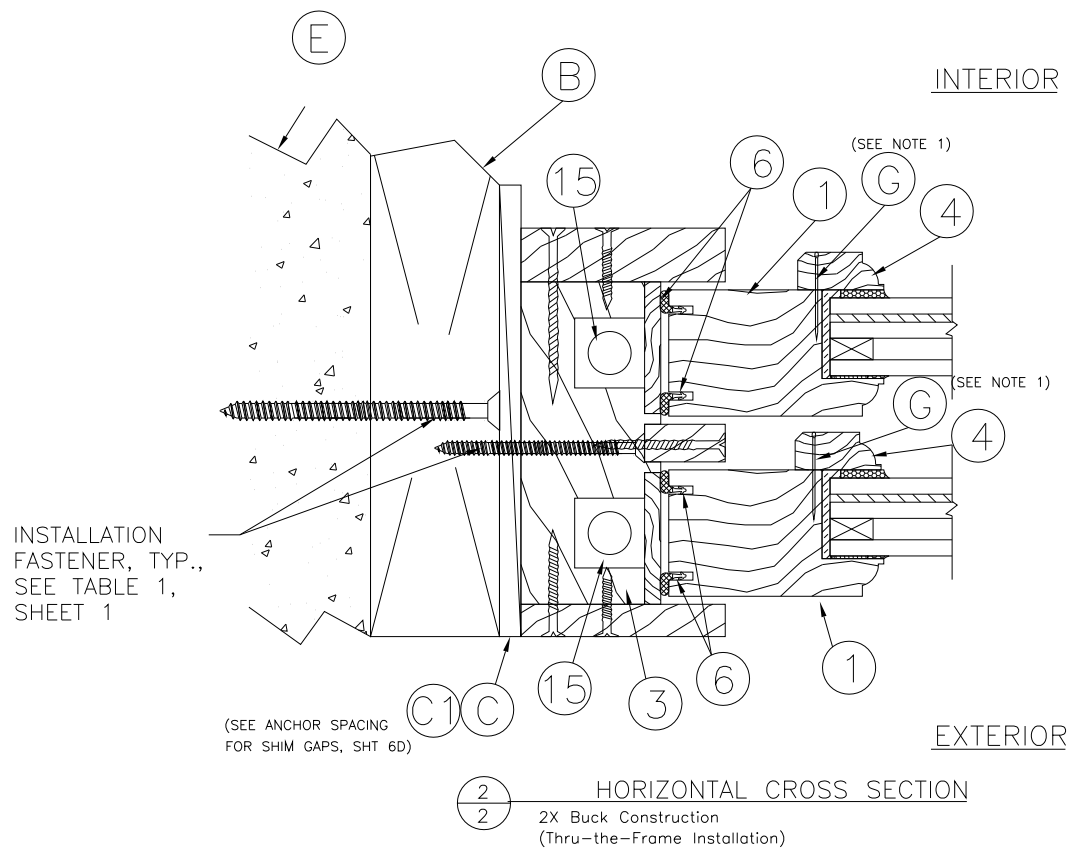
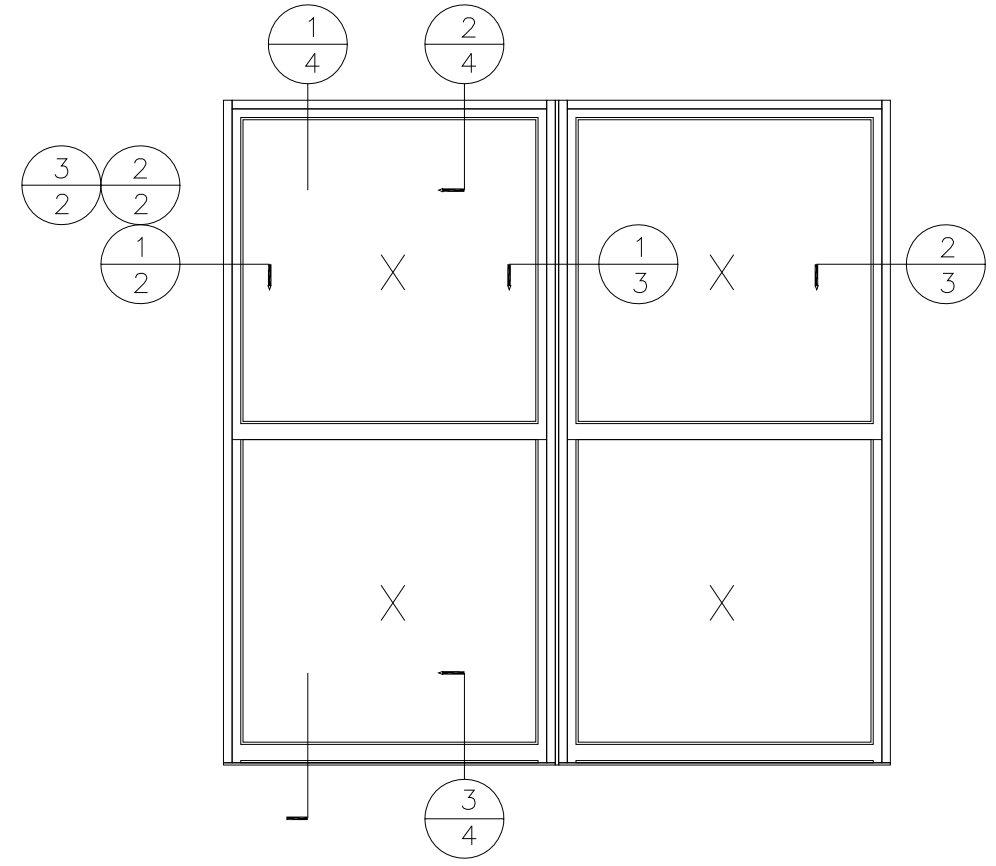
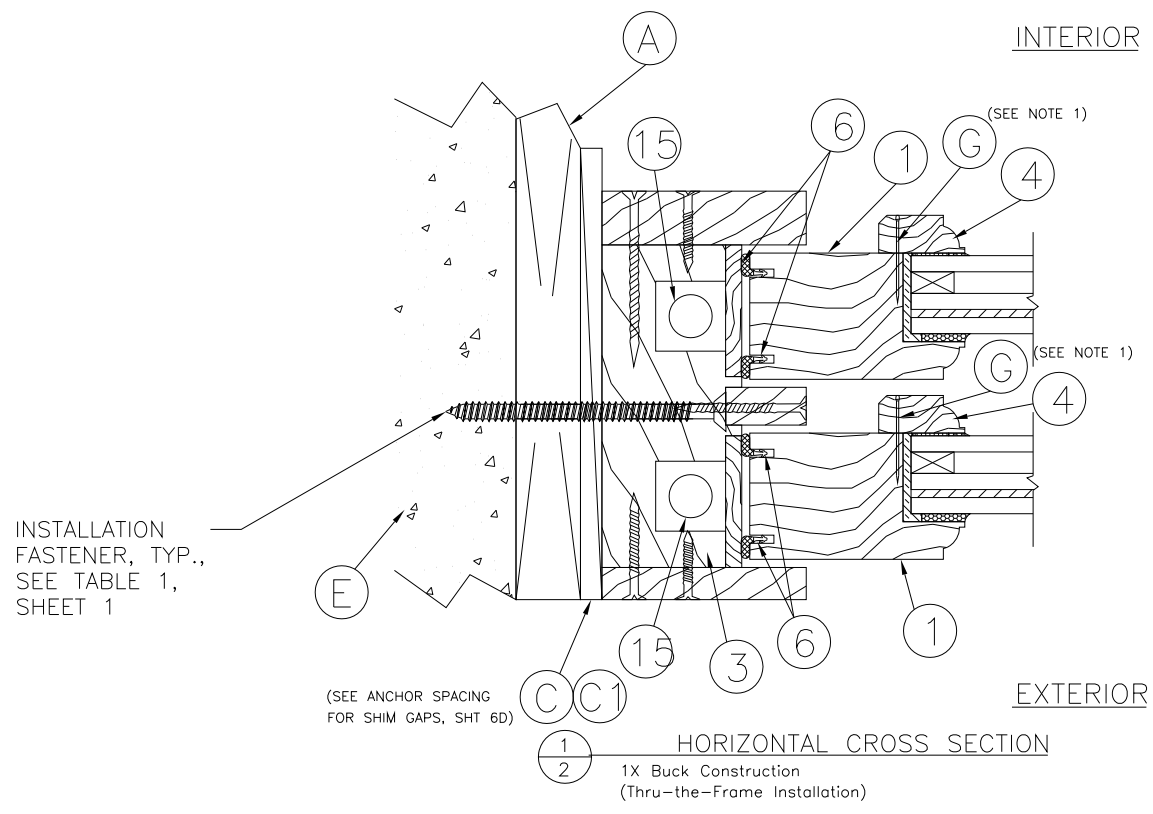

10/18/2023

TE&C
 LUCAS A. TURNER, P.E. FL PE 58201
 TURNER ENGINEERING & CONSULTING, INC.
 PH. 941-380-1574
 2428 OLD MATCHEZ TRACE TRAIL
 CAMDEN, TN 38320

OWW LLC
 3001 Tuvedo Ave., West Palm Beach, FL 33405
 Ph. 561-478-7233 Fax 561-478-7858

Product: SERIES 4500
 TWIN DOUBLE HUNG BALANCE WINDOW

HORIZONTAL
 CROSS SECTIONS

Date: 05-07-14

Scale: None

Drawn: JDS

Dwg. DH-TwinBal
 FL34941.5

Sheet No.
 2D OF 8

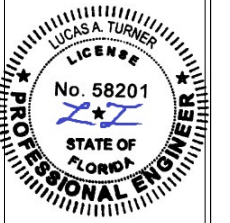

10/18/2023

TE&C
 LUCAS A. TURNER, P.E. FL PE 58201
 TURNER ENGINEERING & CONSULTING, INC.
 PH. 941-380-1574
 2428 OLD MATCHEZ TRACE TRAIL
 CAMDEN, TN 38320

OWW LLC
 3001 Tuvedo Ave., West Palm Beach, FL 33405
 Ph. 561-478-7233 Fax 561-478-7858

Product: SERIES 4500 TWIN DOUBLE HUNG BALANCE WINDOW

Date: 05-07-14
 Scale: None
 Drawn: JDS

HORIZONTAL CROSS SECTIONS

Dwg. DH-TwinBal FL34941.5

Sheet No. 3D OF 8

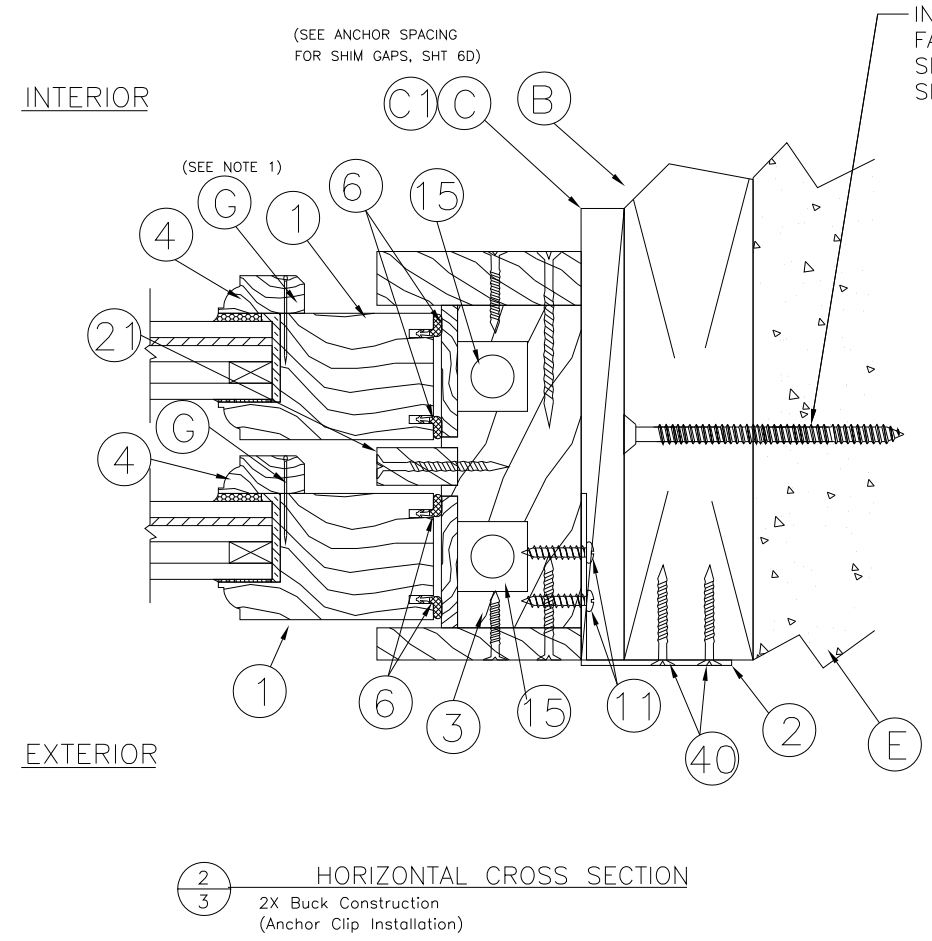
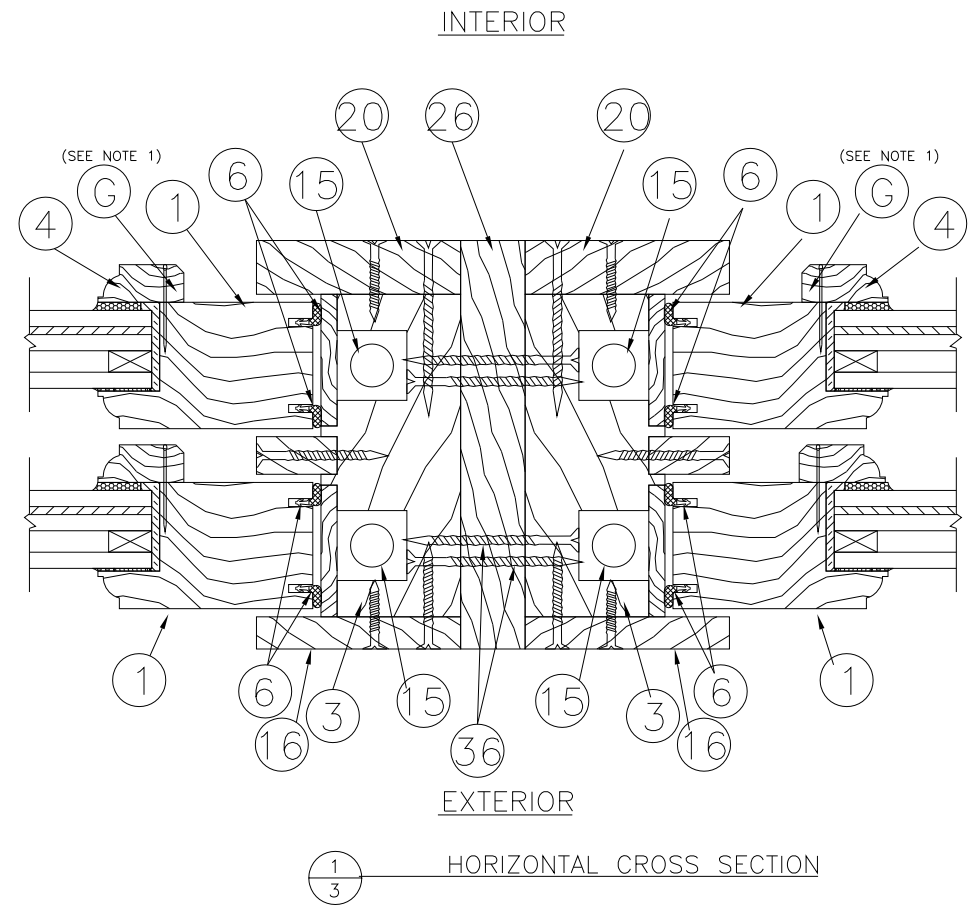

NOTE:
 1. Item #G located 1" from each end then 10" on center.

INSTALLATION FASTENER, TYP., SEE TABLE 1, SHEET 1

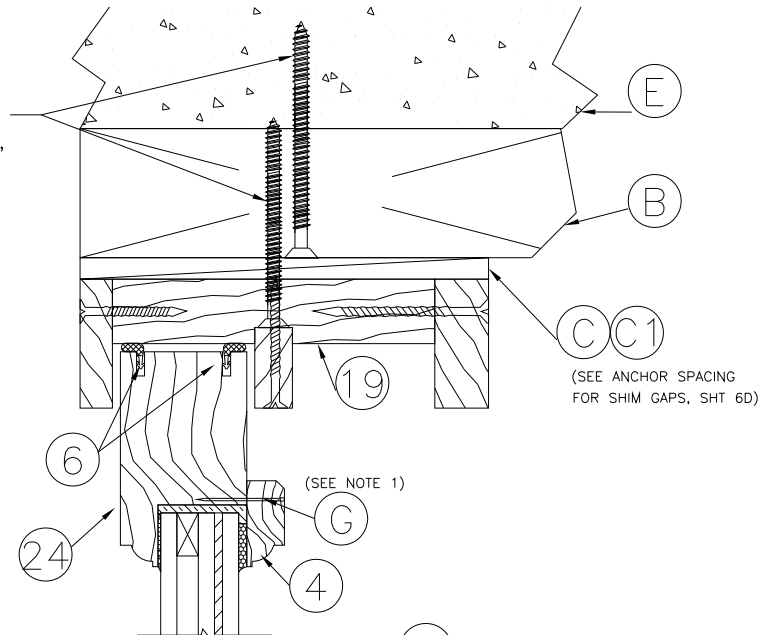

EXTERIOR

INTERIOR

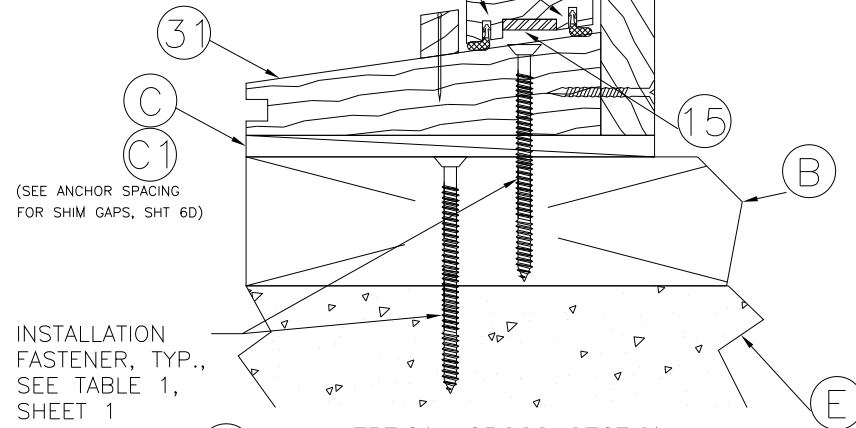
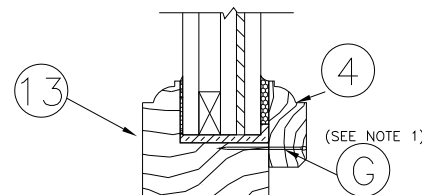
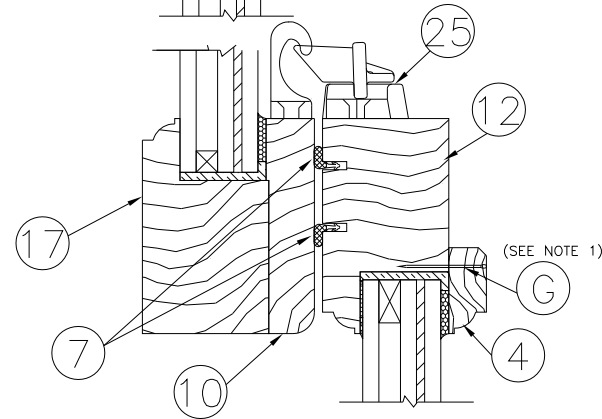

1
4 VERTICAL CROSS SECTION
2X Buck Construction
(Thru-the-Frame Installation)

NOTE:

1. Item #G located 1" from each end then 10" on center.

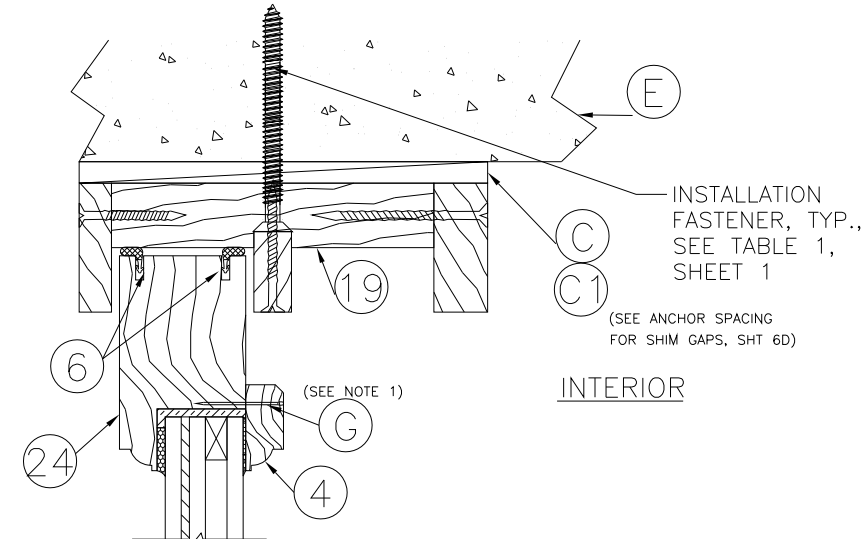

EXTERIOR

INTERIOR

2
4 VERTICAL CROSS SECTION
Direct to masonry
(Thru-the-Frame Installation)

EXTERIOR

INTERIOR

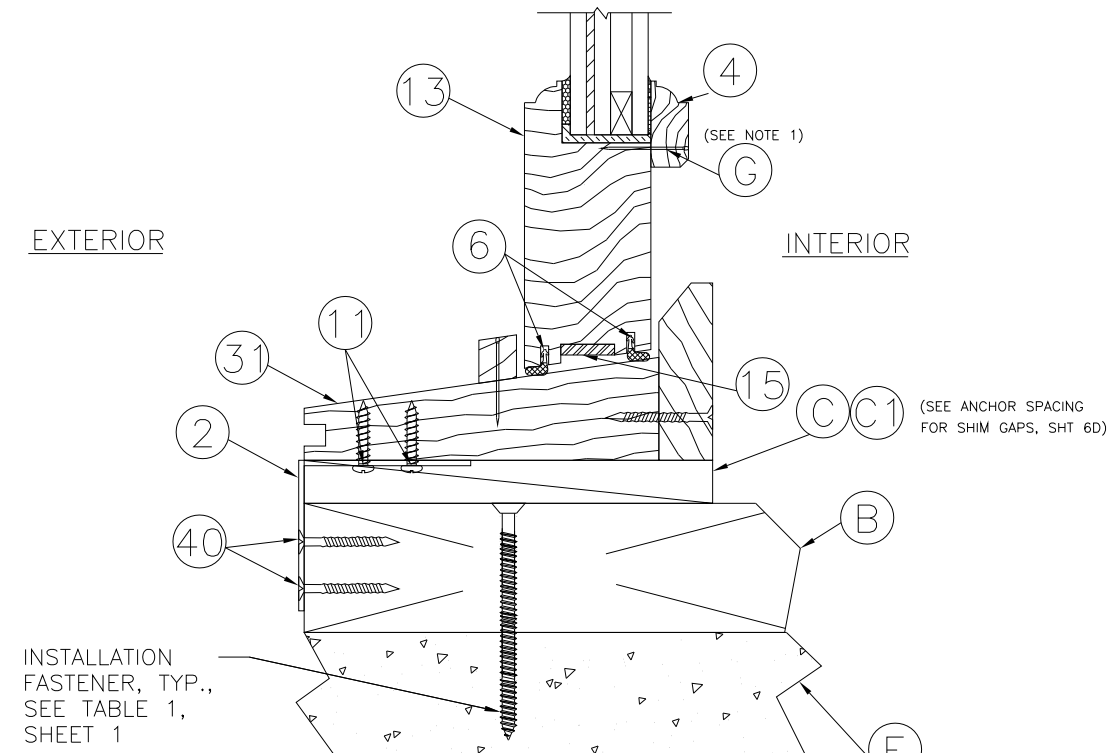

3
4 VERTICAL CROSS SECTION
2X Buck Construction
(Anchor Clip Installation)

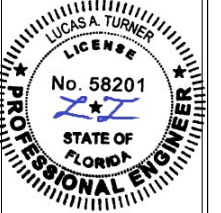

10/18/2023

TE&C
LUCAS A. TURNER, P.E. FL PE 58201
TURNER ENGINEERING & CONSULTING, INC.
PH. 941-380-1574
2428 OLD MATCHEZ TRACE TRAIL
CAMDEN, TN 38320

OWW LLC
3001 Tuvedo Ave., West Palm Beach, FL 33405
Ph. 561-478-7233 Fax 561-478-7858

Product: SERIES 4500
TWIN DOUBLE HUNG BALANCE WINDOW
Date: 05-07-14
Scale: None
Drawn: JDS

VERTICAL CROSS SECTIONS

Dwg. DH-TwinBal
FL34941.5

Sheet No.
4D OF 8

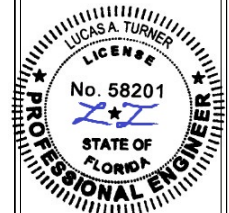

10/18/2023

TE&C
 LUCAS A. TURNER, P.E. FL PE 58201
 TURNER ENGINEERING & CONSULTING, INC.
 PH. 941-380-1574
 2428 OLD MATCHEZ TRACE TRAIL
 CAMDEN, TN 38320

OWW LLC
 3001 Tuvedo Ave., West Palm Beach, FL 33405
 Ph. 561-478-7233 Fax 561-478-7858

Product: SERIES 4500
 TWIN DOUBLE HUNG BALANCE WINDOW

Date: 05-07-14
 Scale: None
 Drawn: JDS

Dwg. DH-TwinBal
 FL34941.5

Sheet No.
 5D OF 8

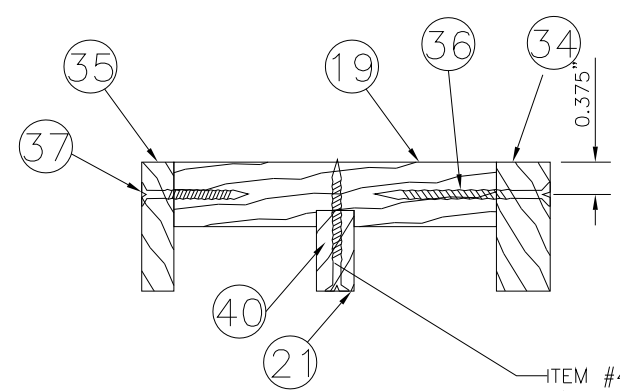

SECTION A-A

ITEM #40 LOCATED 4" FROM EACH END AND 2 MORE EQUALLY SPACED (4) TOTAL

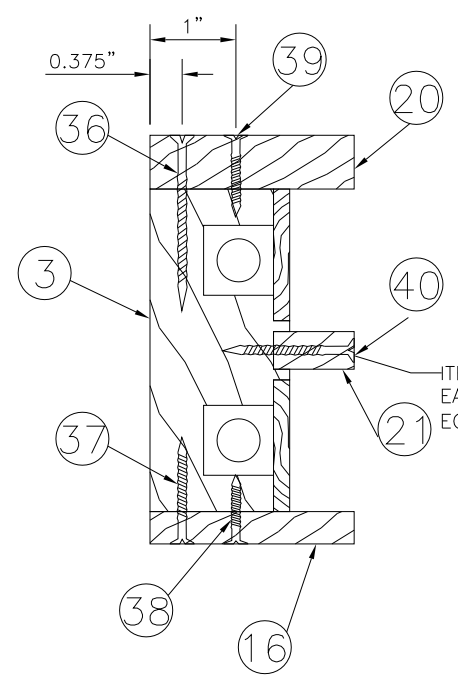

SECTION C-C

ITEM #40 LOCATED 4" FROM EACH END AND 8 MORE EQUALLY SPACED (10) TOTAL

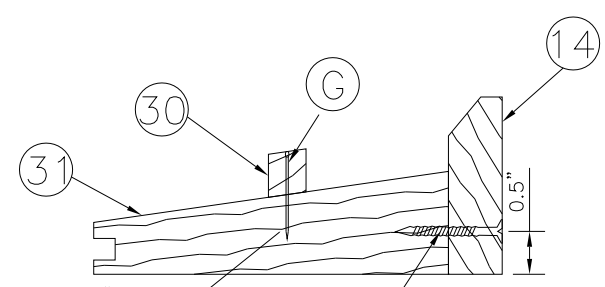

SECTION B-B

ITEM #G LOCATED 1" FROM EACH END AND 8 MORE EQUALLY SPACED (10) TOTAL

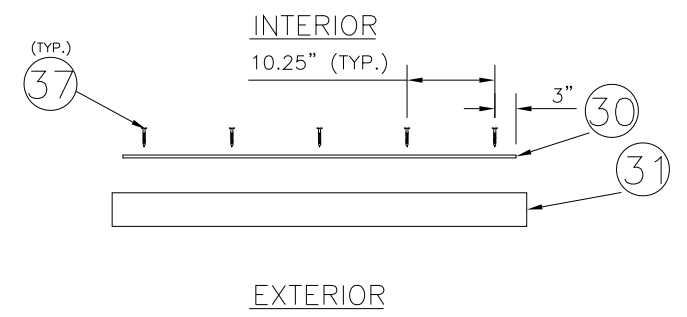
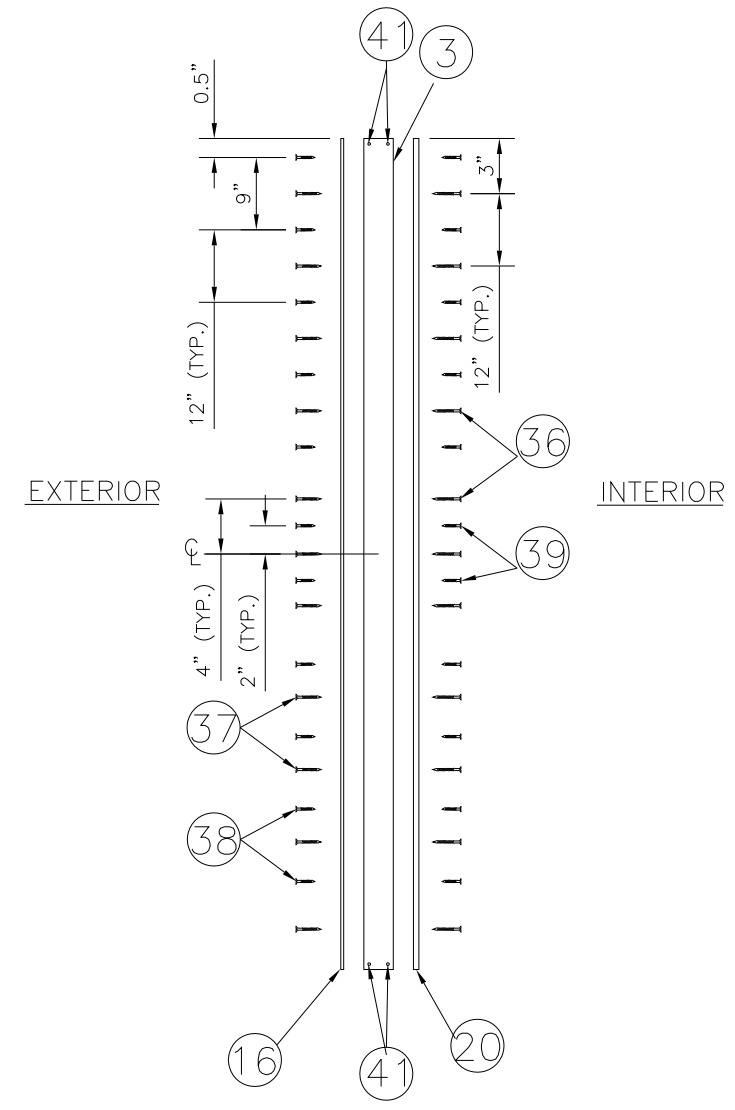
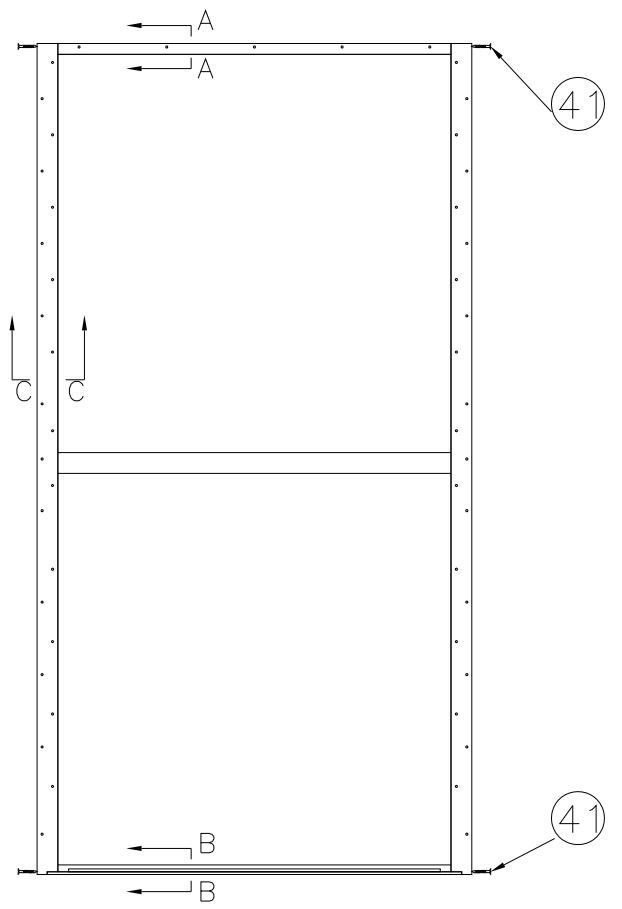
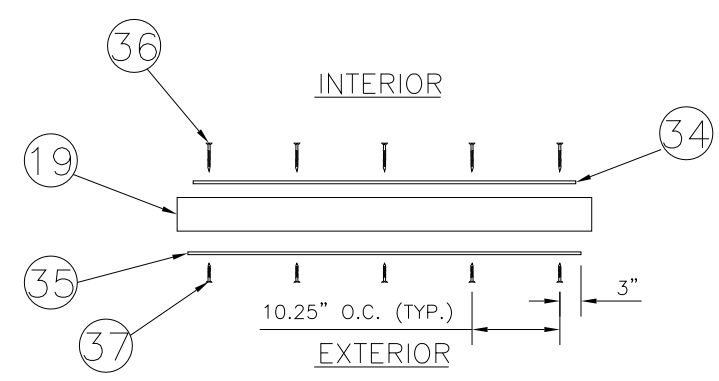

EXTERIOR

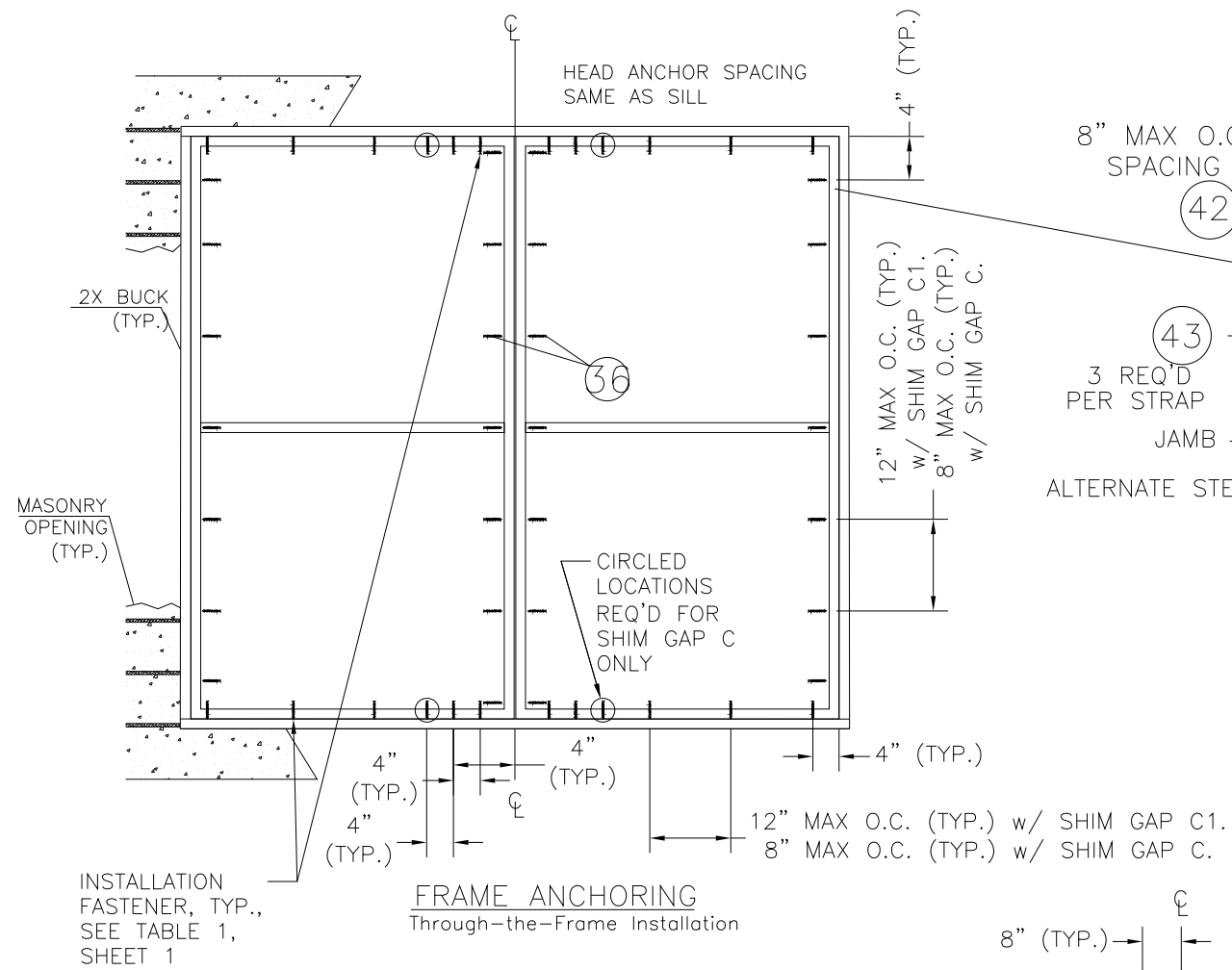

NOTE: STAGGER ANCHORS AS NEEDED TO ENSURE 4" MIN. SEPARATION BETWEEN ANY TWO BUCK AND/OR THROUGH-FRAME ANCHORS, WHILE NOT EXCEEDING MAX. ANCHOR SPACINGS NOTED IN DETAILS (MAY NEED ADDITIONAL FASTENERS).

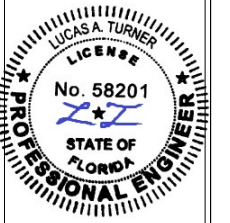
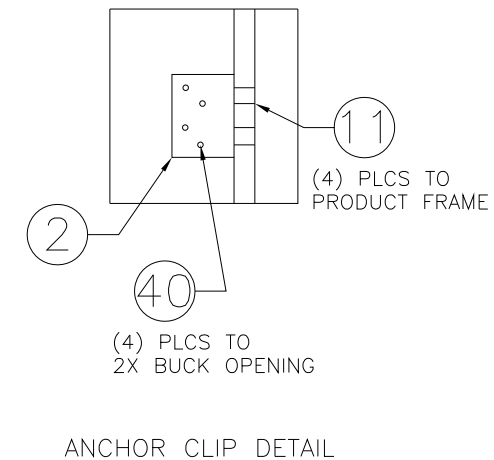
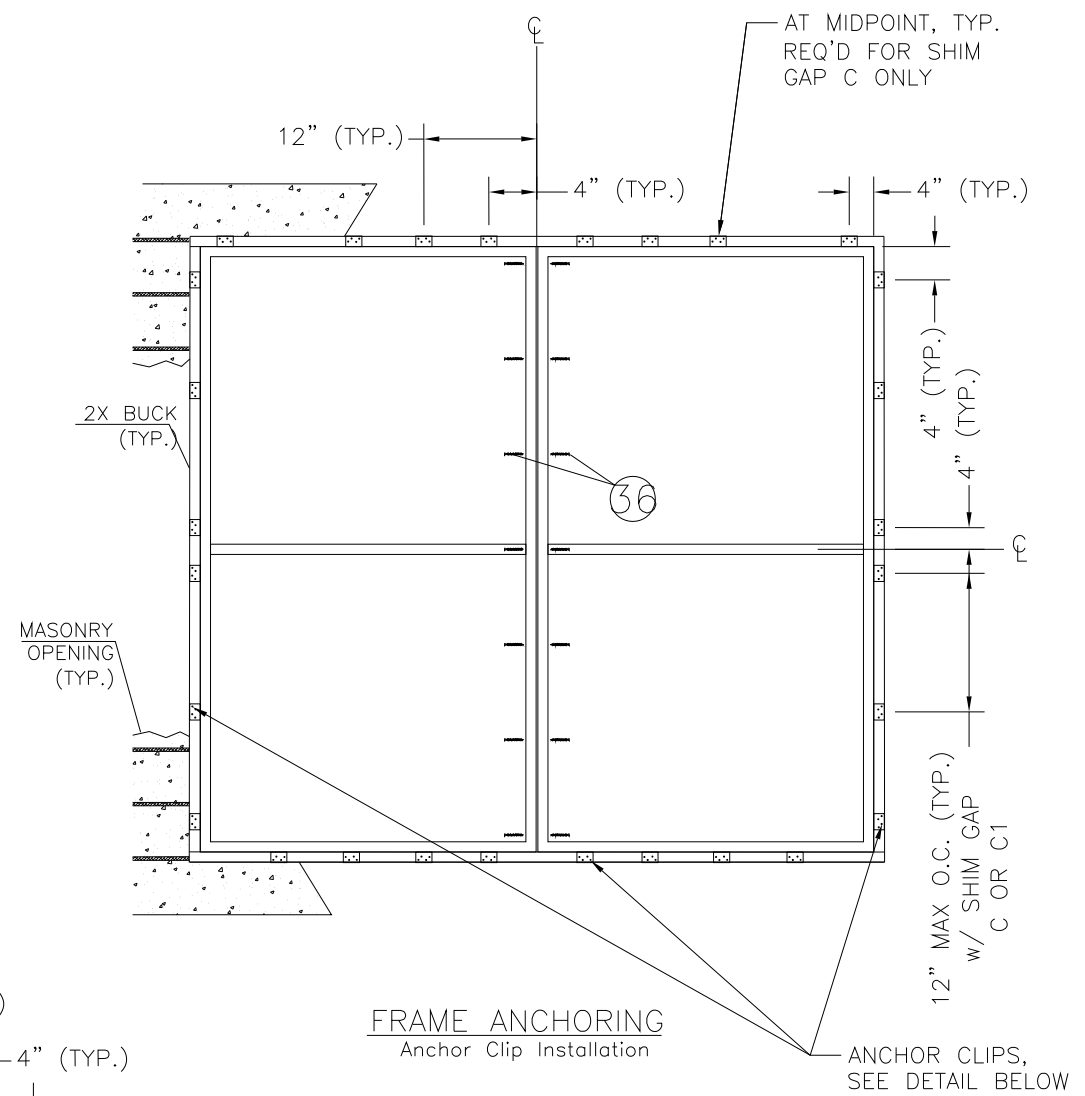
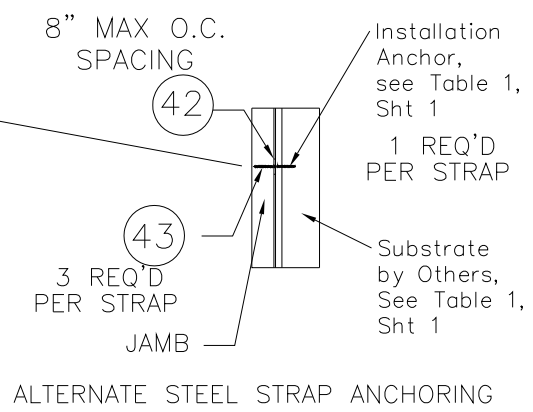
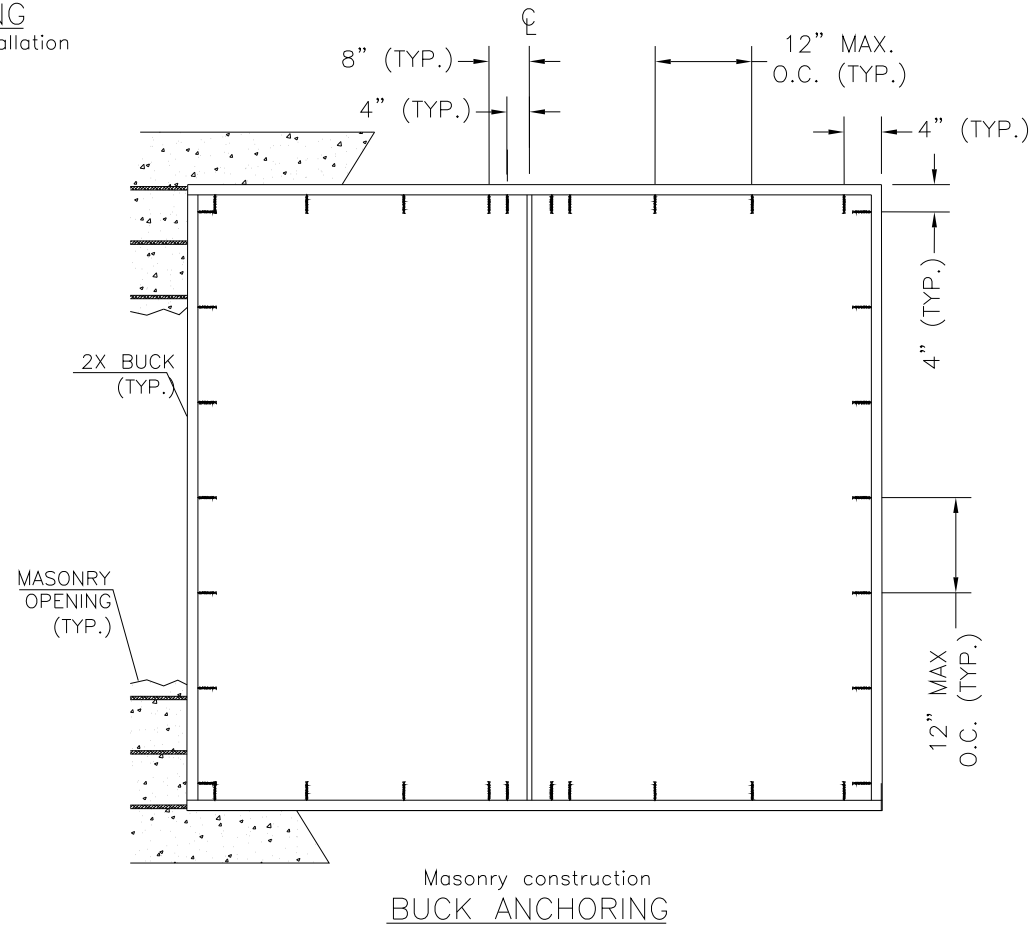

10/18/2023

TE&C
LUCAS A. TURNER, P.E. FL PE 58201
TURNER ENGINEERING & CONSULTING, INC.
PH. 941-380-1574
2428 OLD MATCHEZ TRACE TRAIL
CAMDEN, TN 38320

OWW LLC
3001 Tuveda Ave., West Palm Beach, FL 33405
Ph. 561-478-7233 Fax 561-478-7858

Product: SERIES 4500
TWIN DOUBLE HUNG BALANCE WINDOW

Date: 05-07-14
Scale: None
Drawn: JDS

BUCK & FRAME ANCHORING

Dwg. DH-TwinBal
FL34941.5

Sheet No.
6D OF 8

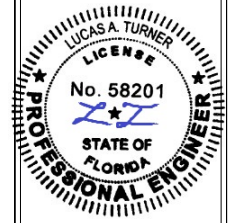
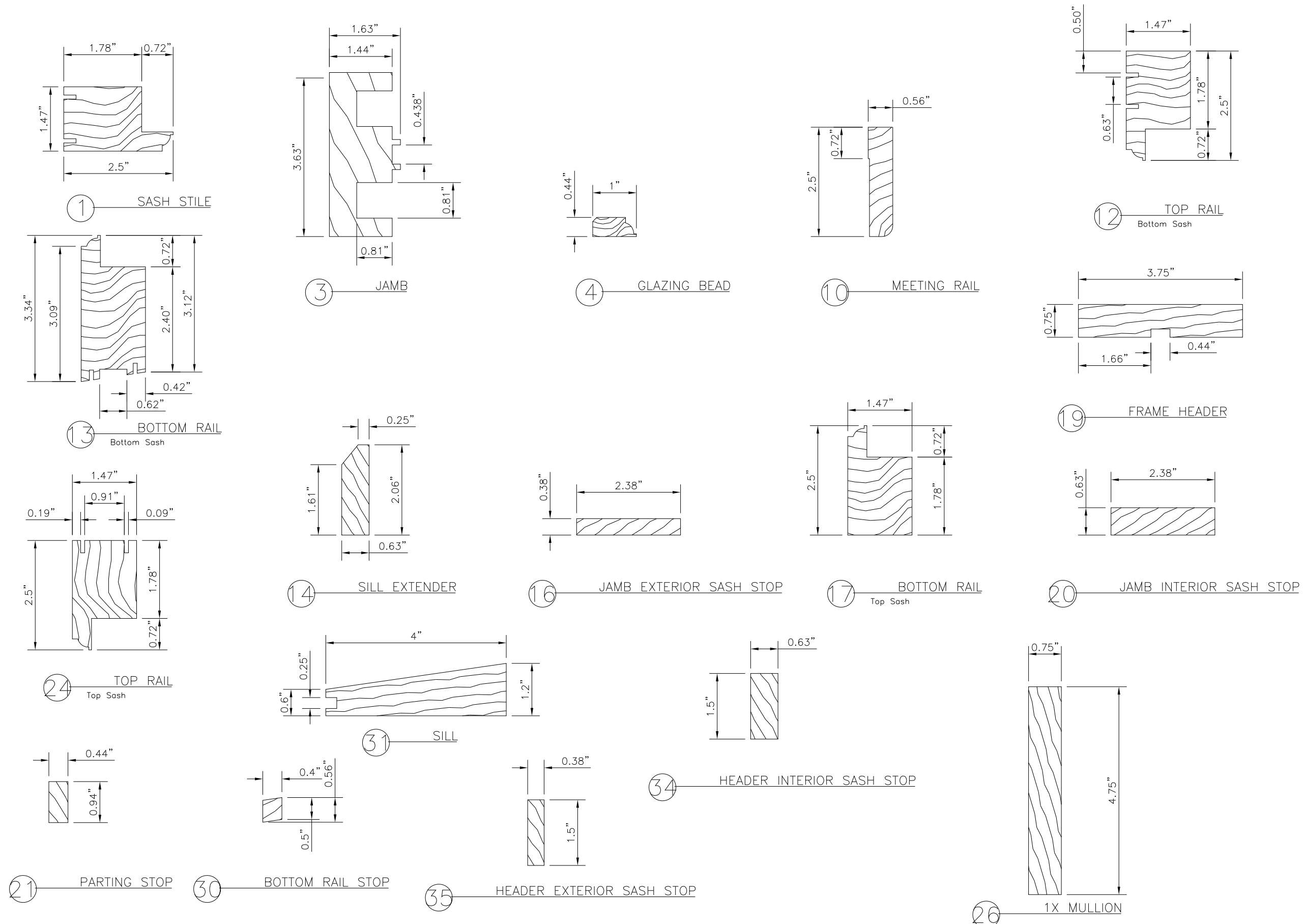

10/18/2023

TE&C
LUCAS A. TURNER, P.E. FL PE 58201
TURNER ENGINEERING & CONSULTING, INC.
PH. 941-380-1574
2428 OLD NATCHEZ TRACE TRAIL
CAMDEN, TN 38320

OWW LLC
3001 Tuvedo Ave., West Palm Beach, FL 33405
Ph. 561-478-7233 Fax 561-478-7858

Product: SERIES 4500
TWIN DOUBLE HUNG BALANCE WINDOW

COMPONENTS

Date: 05-07-14
Scale: None
Drawn: JDS

Dwg. DH-TwinBal
FL34941.5

Sheet No.
7D OF 8

BILL OF MATERIALS		
ITEM #	DESCRIPTION	MATERIAL
A	1X BUCK (SG>=0.42)	WOOD
B	2X BUCK (SG>=0.42)	WOOD
C	1/2" MAX.SHIM SPACE	-
C1	1/4" MAX.SHIM SPACE	-
E	SOLID CONCRETE CONFORMING TO ACI 301 OR CMU BLOCK CONFORMING TO ASTM C90 (SEE TABLE 1, SHT 1)	MASONRY
G	23GA X 1" BRAD	STEEL
1	SASH STILE	WOOD
2	ANCHOR BRACKET (Simpson Strong-Tie A23Z)	STEEL
3	JAMB	WOOD
4	GLAZING BEAD	WOOD
6	WEATHERSTRIP QEZD100 BY SCHLEGEL	FOAM
10	MEETING RAIL	WOOD
11	#8 X 3/4" LATH SCREWS	WOOD
12	BOTTOM SASH TOP RAIL	WOOD
13	BOTTOM SASH BOTTOM RAIL	WOOD
14	SILL EXTENDER	WOOD
15	ULTRA-LIFT SPIRAL TUBE BALANCE BY CALDWELL	-
16	EXTERIOR SASH STOP	WOOD
17	TOP SASH BOTTOM RAIL	WOOD
19	FRAME HEADER	WOOD
20	INTERIOR SASH STOP	WOOD
21	PARTING STOP	WOOD
24	TOP SASH TOP RAIL	WOOD
25	GATE HOUSE SASH LOCK, MOD #837773	-
26	1X MULLION (SAPELE SG >=0.55)	WOOD
30	BOTTOM RAIL STOP	WOOD
31	SILL	WOOD
34	HEADER INTERIOR SASH STOP	WOOD
35	HEADER EXTERIOR SASH STOP	WOOD
36	#8 X 2" PFH WOOD SCREW	STEEL
37	#8 X 1-1/4" PFH WOOD SCREW	STEEL
38	#8 X 3/4" PFH WOOD SCREW	STEEL
39	#8 X 1" PFH WOOD SCREW	STEEL
40	#8 X 1-1/2" PFH WOOD SCREW	STEEL
41	#8 X 2-1/2" PFH WOOD SCREW	STEEL
42	STEEL ANCHOR STRAP 1-1/4" X 4" X 1/8"	STEEL
43	#10 X 3/4" PFH WOOD SCREW	STEEL

NOTE: ALL WINDOW FRAME WOOD IS SG=0.55 MIN. (SAPELE OR SIMILAR)

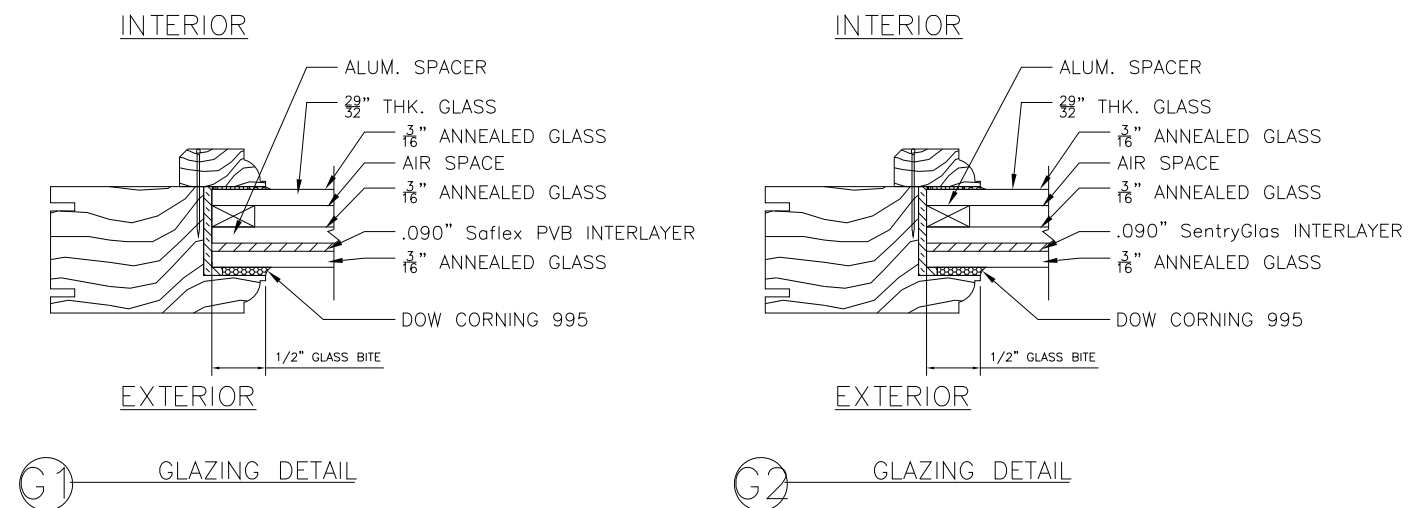

NOTE: GLAZING LARGER THAN 36" WIDE REQUIRES TWO (2) SETTING BLOCKS CONFORMING TO FBC SECTION 2411.3.3.1.

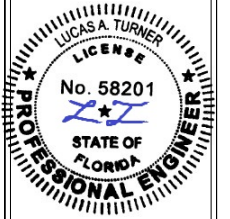

10/18/2023

TE&C
LUCAS A. TURNER, P.E. FL PE 58201
TURNER ENGINEERING & CONSULTING, INC.
PH. 941-380-1574
2428 OLD MATCHEZ TRACE TRAIL
CAMDEN, TN 38320

OWW LLC
3001 Tuvedo Ave., West Palm Beach, FL 33405
Ph. 561-478-7233 Fax 561-478-7858

Product: 4500
SERIES: TWIN DOUBLE HUNG BALANCE WINDOW
Date: 05-07-14
Scale: None
Drawn: JDS
BILL OF MATERIALS, COMPONENTS
& GLAZING DETAILS

Dwg. DH-TwinBal
FL34941.5

Sheet No.
8D OF 8