

# FIXED CASEMENT WINDOW – "IMPACT" BY OWW LLC

DESIGN PRESSURE = + 75.0 PSF, – 75.0 PSF

## GENERAL NOTES

1. This product has been evaluated and is in compliance with 8th Edition (2023) Florida Building Code (FBC) structural requirements including the "High Velocity Hurricane Zone" (HVHZ).
2. Product anchors shall be as listed and spaced as shown on details. Anchor embedment to base materials shall be beyond wall dressing or stucco. All anchors used shall be of a material or have a coating compatible with pressure treated wood if used, and all other window materials.
3. When used in the "HVHZ" this product complies with Section 1626 of the FBC and does not require an impact resistant covering.
4. The opening substrate materials (framing, masonry, bucks) are by others and must be properly designed and installed to transfer superimposed loads to the structure. For 2X stud framing construction, anchoring of these units shall be the same as that shown for 2X buck masonry construction. Wood bucks over masonry, if used, shall be pressure treated, with either a treatment or coating compatible with this product and anchors.
5. All window frame wood to be Specific Gravity = 0.50 min. (Mahogany or similar).
6. Site conditions that deviate from the details of this drawing require further engineering analysis by a licensed engineer or registered architect.
7. This product has been laboratory tested to meet the water infiltration requirements for "HVHZ." Sealing and flashing strategies for overall water infiltration resistance of the field-installed product shall be the responsibility of others and are not addressed by this document.

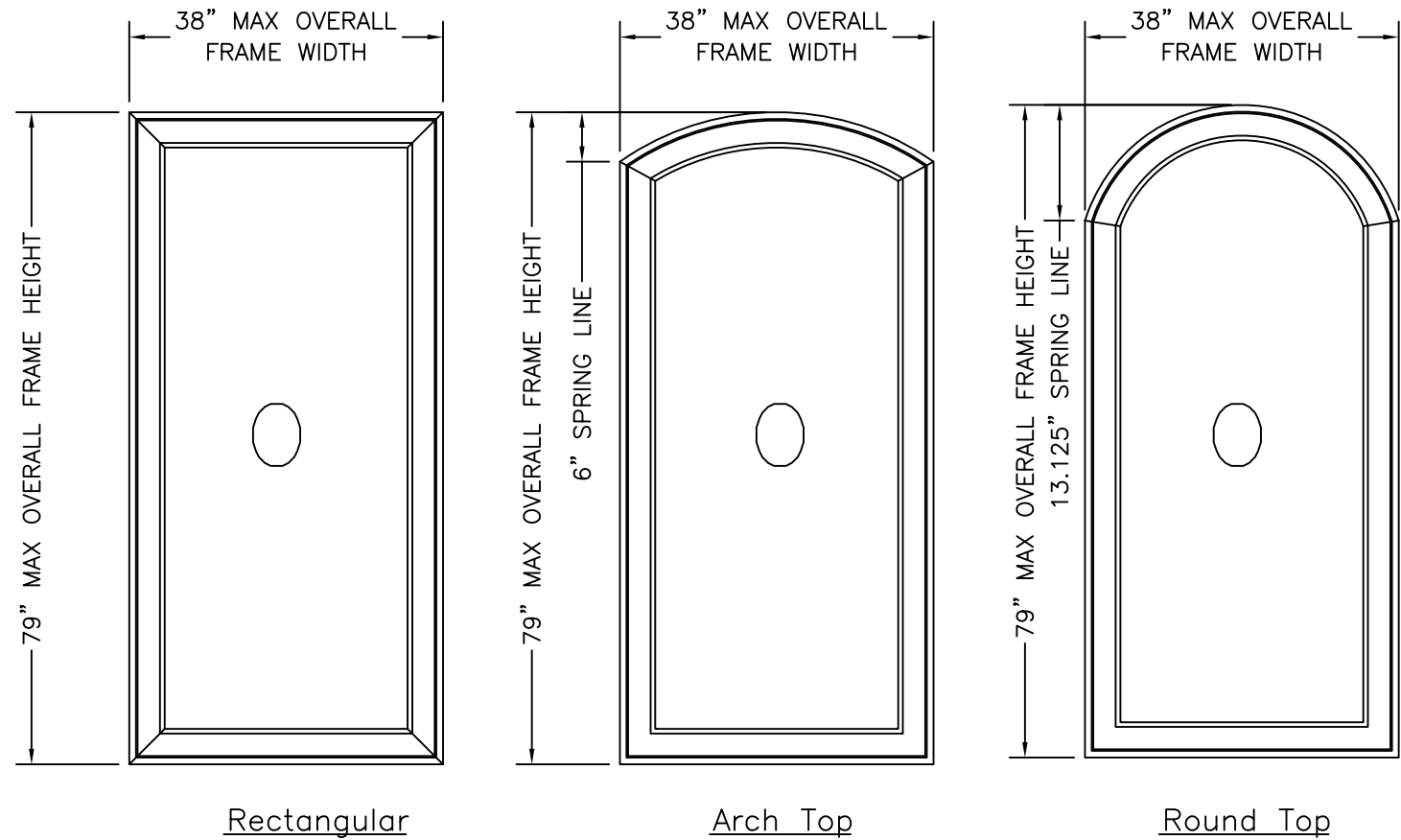
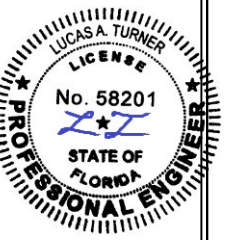

TABLE 1. QUALIFIED ANCHOR INFORMATION

ID	SUBSTRATE	ANCHOR	MIN. EMBEDMENT	MIN. EDGE DISTANCE
A	SOLID UNCRACKED CONCRETE (2850 PSI MIN.)	1/4" ELCO COATED CARBON STEEL ULTRACON	1 3/8"	1"
B	GROUT-FILLED CMU (ASTM C-90) (JAMBS ONLY)	1/4" ELCO COATED CARBON STEEL ULTRACON	1 3/4"	2 1/2"
C	SOLID UNCRACKED CONCRETE (2000 PSI MIN.)	1/4" ITW COATED CARBON STEEL TAPCON	1 1/2"	1 1/2"
D	HOLLOW CMU (117 PCF MIN.) (JAMBS ONLY)	1/4" ITW COATED CARBON STEEL TAPCON	1"	2"
E	CONCRETE (3000 PSI MIN)	1/4" HILTI COATED CARBON STEEL OR STAINLESS STEEL KWIK-CON II	1"	2 1/2"
F	HOLLOW OR GROUT-FILLED CMU (ASTM C-90)	1/4" HILTI COATED CARBON STEEL OR STAINLESS STEEL KWIK-CON II	1"	2 1/2"
G	2x MIN. SOUTHERN PINE WOOD (G=0.55 MIN)	#12 GRADE 5 WOOD SCREW	1 1/2"	1"
H	16 GAUGE (0.060") MIN. STEEL STUD (33 KSI YIELD MIN.) OR 1/8" MIN. ALUMINUM (6063-T5 MIN.)	#14 ITW TEKS SELF-DRILLING SCREW	FULL + 3 THREADS	1/2"

## TABLE OF CONTENTS

SHEET #	DESCRIPTION
1	Typical elevation, design pressures & general notes
2	Horizontal cross sections
3	Vertical cross sections
4	Buck and frame anchoring
5	Bill of materials, components & glazing details



10/18/2023

TE&C  
LUCAS A. TURNER, P.E. FL PE 58201  
TURNER ENGINEERING & CONSULTING, INC.  
PH. 941-380-1574  
2428 OLD NATCHEZ TRACE TRAIL  
CAMDEN, TN 38320

OWW LLC  
3001 Tuxedo Ave., West Palm Beach, FL 33405  
Ph. 561-478-7233 Fax 561-478-7858

Product: FIXED CASEMENT WINDOW  
Date: 01-18-18  
Scale: None  
Drawn: JDS

Dwg: FCA-0  
FL34943.1

Sheet No.  
1D OF 5

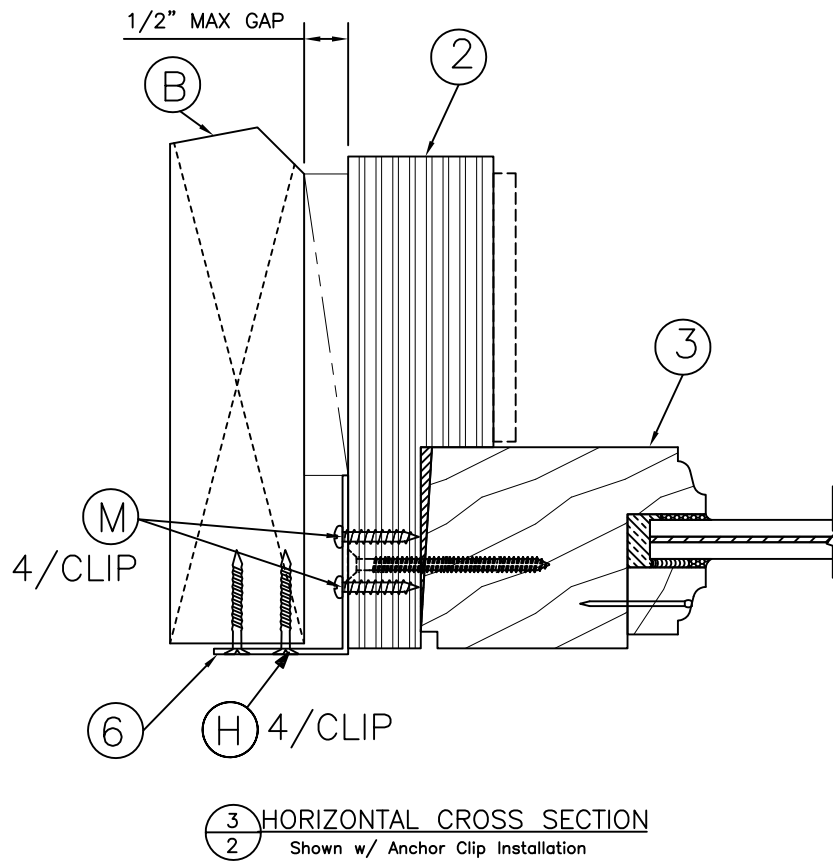
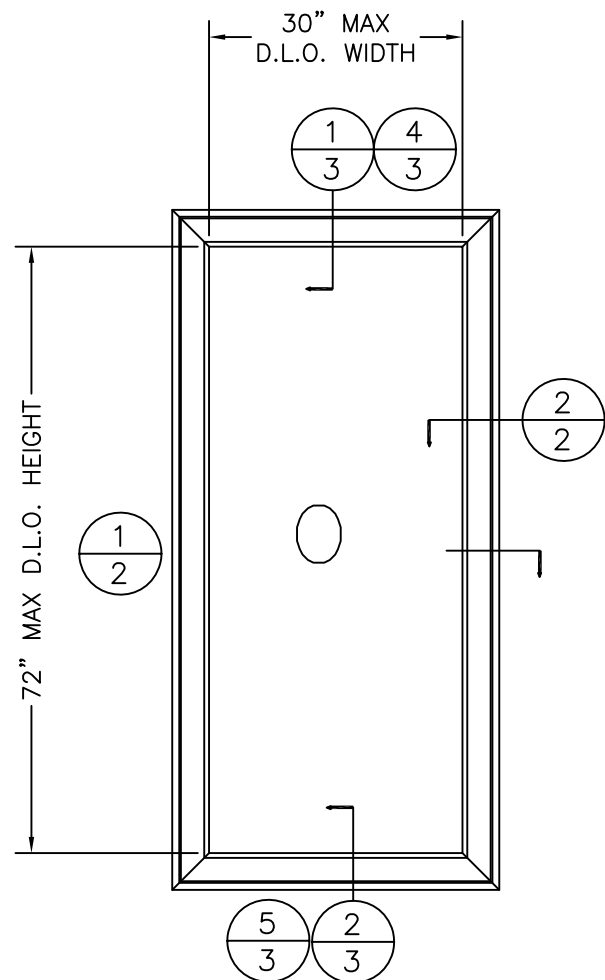

3 HORIZONTAL CROSS SECTION  
2 Shown w/ Anchor Clip Installation

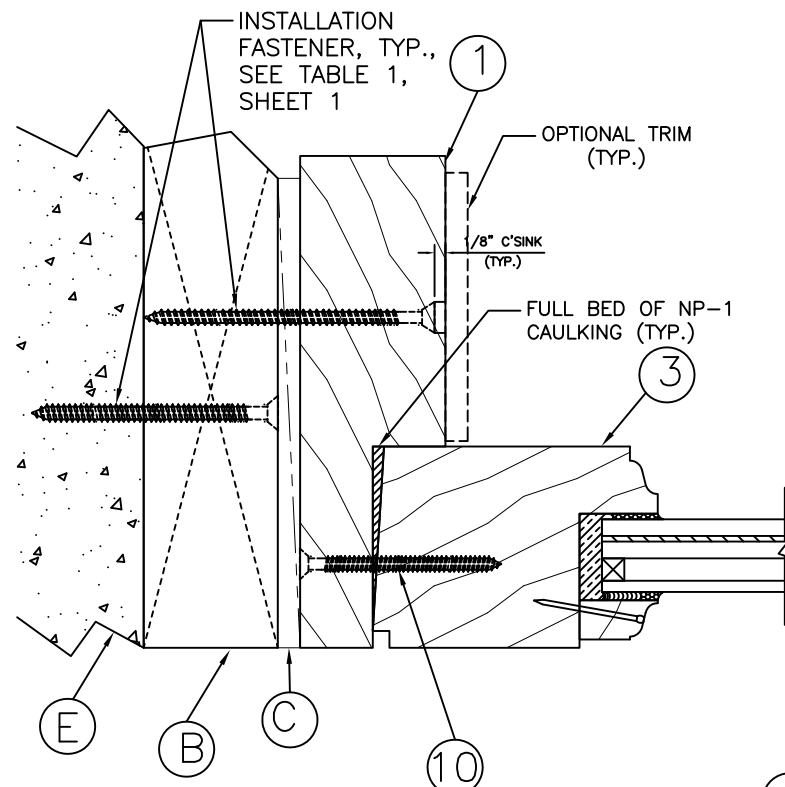
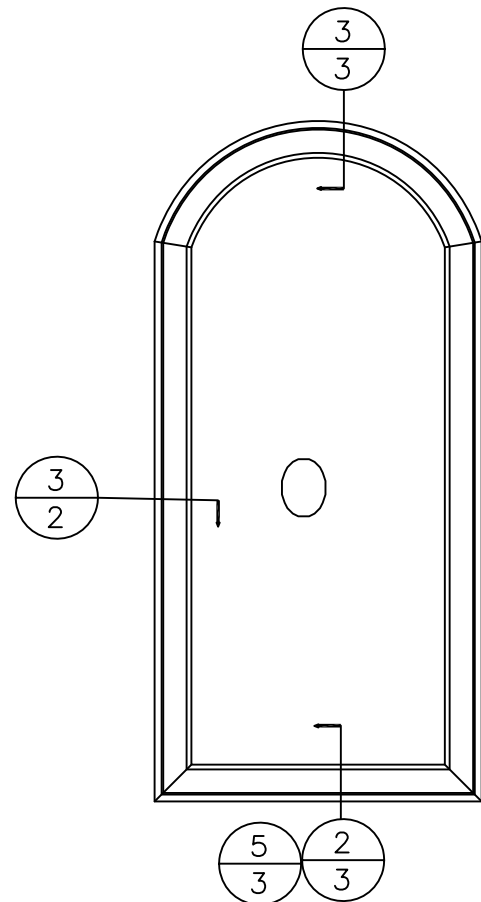

1 HORIZONTAL CROSS SECTION  
2 Shown w/ 2X Buck Construction

LOCATE 3" FROM EACH  
END & 12" O.C.  
THEREAFTER

INTERIOR

EXTERIOR

INTERIOR

EXTERIOR

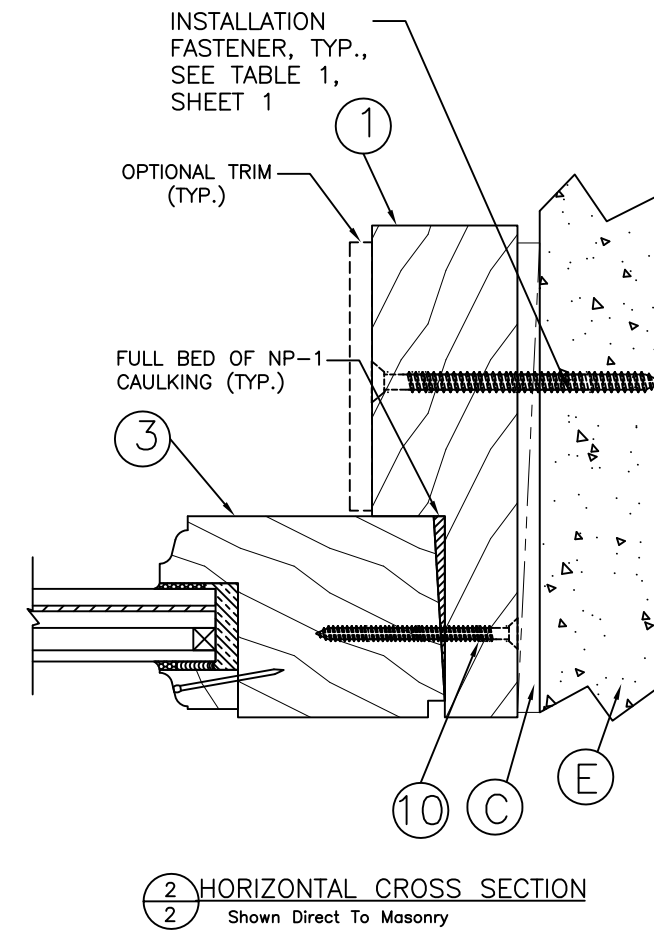

2 HORIZONTAL CROSS SECTION  
2 Shown Direct To Masonry

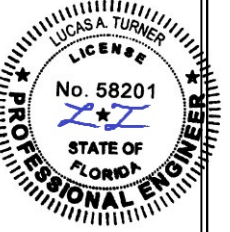
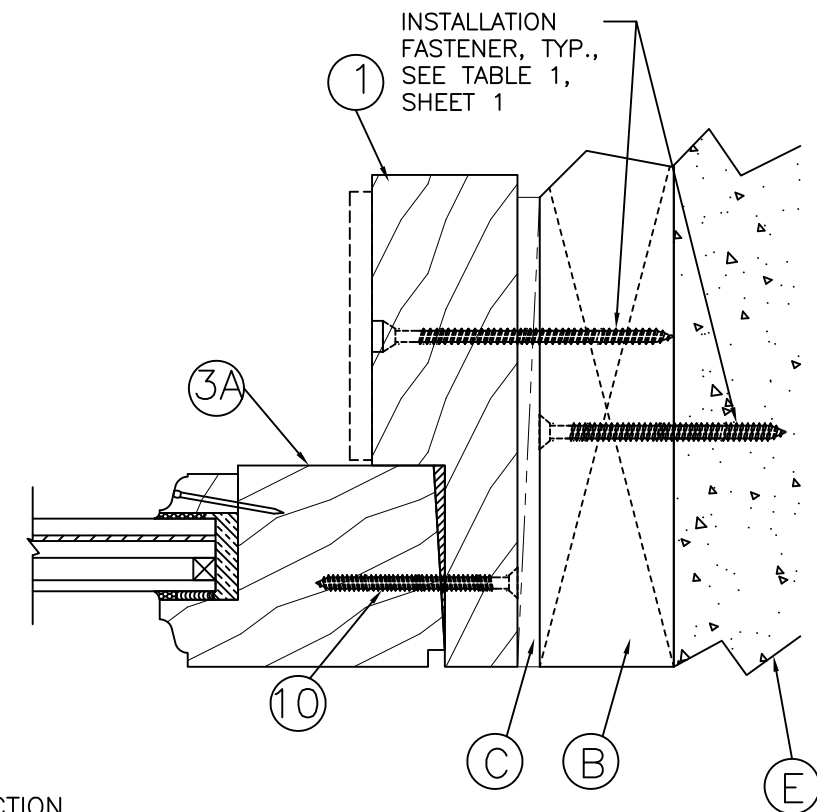

10/18/2023

TE&C  
LUCAS A. TURNER, P.E. FL PE 58201  
TURNER ENGINEERING & CONSULTING, INC.  
PH. 941-380-1574  
2428 OLD NATCHEZ TRACE TRAIL  
CAMDEN, TN 38320

OWW LLC  
3001 Tuxedo Ave., West Palm Beach, FL 33405  
Ph. 561-478-7233 Fax 561-478-7858

Product: FIXED CASEMENT WINDOW

Date: 01-18-18  
Scale: None  
Drawn: JDS

Dwg: FCA-0  
FL34943.1

Sheet No.  
2D OF 5

HORIZONTAL CROSS SECTIONS

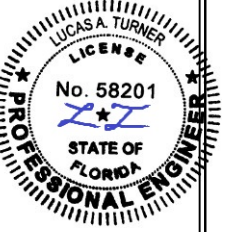

10/18/2023

TE&C  
 LUCAS A. TURNER, P.E. FL PE 58201  
 TURNER ENGINEERING & CONSULTING, INC.  
 PH. 941-380-1574  
 2428 OLD NATCHEZ TRACE TRAIL  
 CAMDEN, TN 38320

OWW LLC  
 3001 Tuxedo Ave., West Palm Beach, FL 33405  
 Ph. 561-478-7233 Fax 561-478-7858

Product: FIXED CASEMENT WINDOW  
 Date: 01-18-18  
 Scale: None  
 Drawn: JDS

Dwg: FCA-0  
 FL34943.1  
 Sheet No.  
 3D OF 5

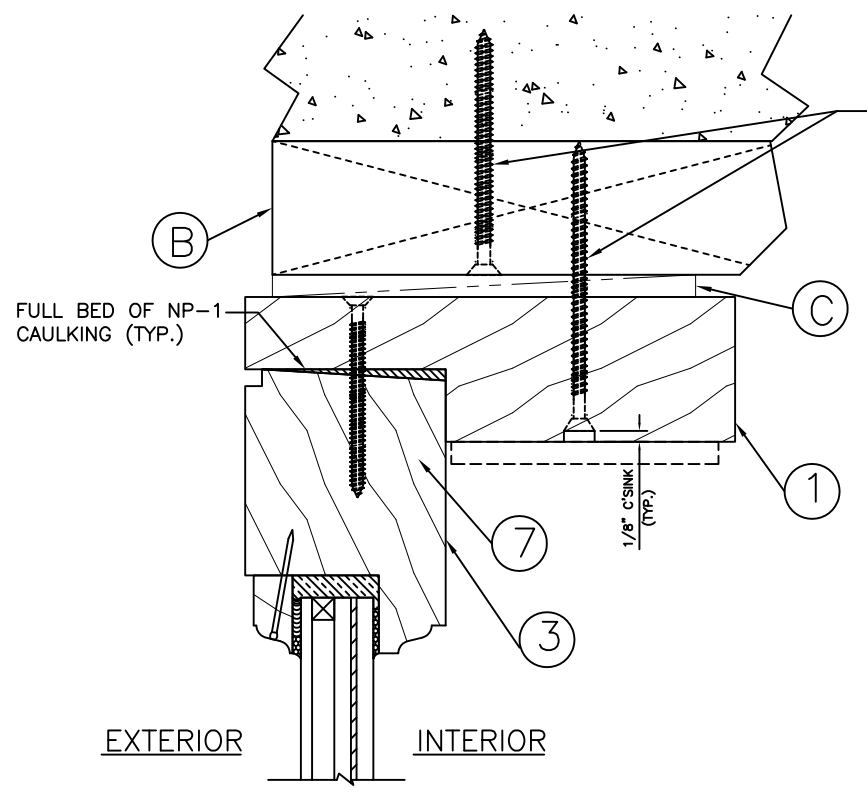

1 VERTICAL CROSS SECTION  
 3 Shown w/ 2X Buck Construction

INSTALLATION FASTENER, TYP., SEE TABLE 1, SHEET 1

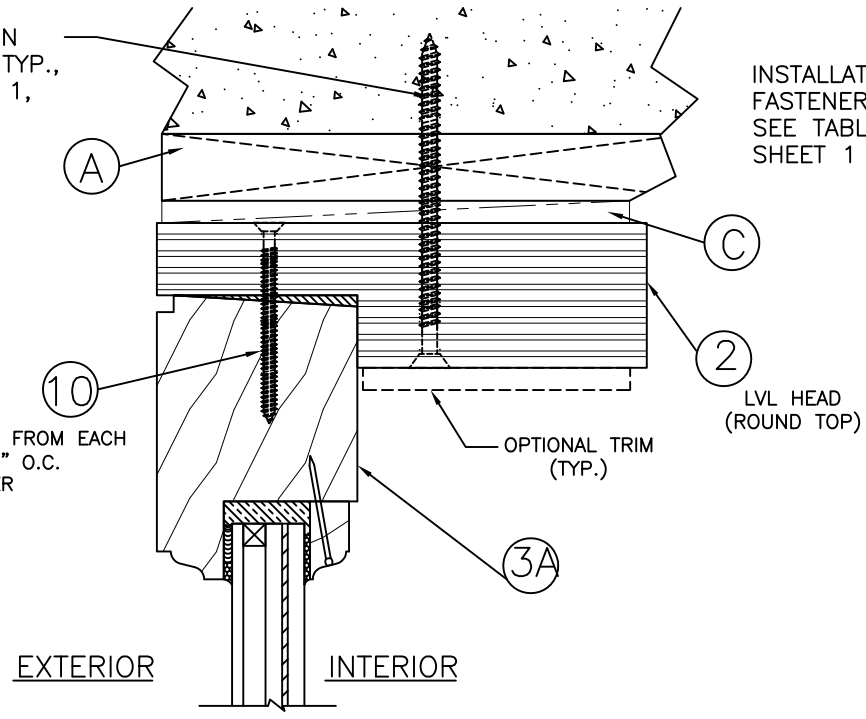

3 VERTICAL CROSS SECTION  
 3 Shown w/ 1X Buck Construction

INSTALLATION FASTENER, TYP., SEE TABLE 1, SHEET 1

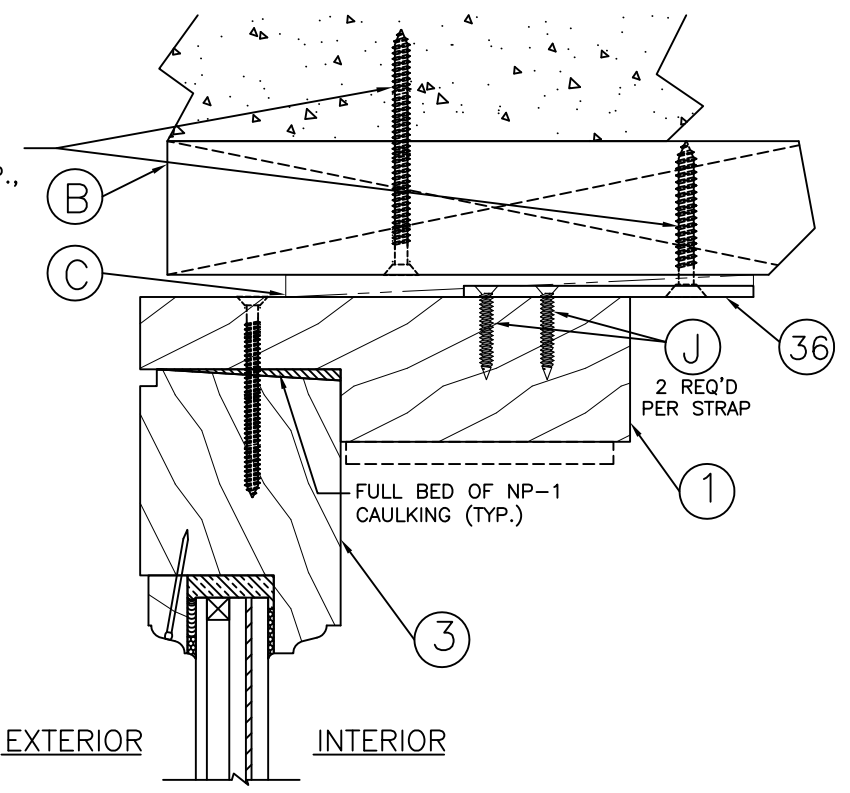

5 VERTICAL CROSS SECTION  
 3 Shown w/ 2X Buck Construction w/ Steel Strap Anchor

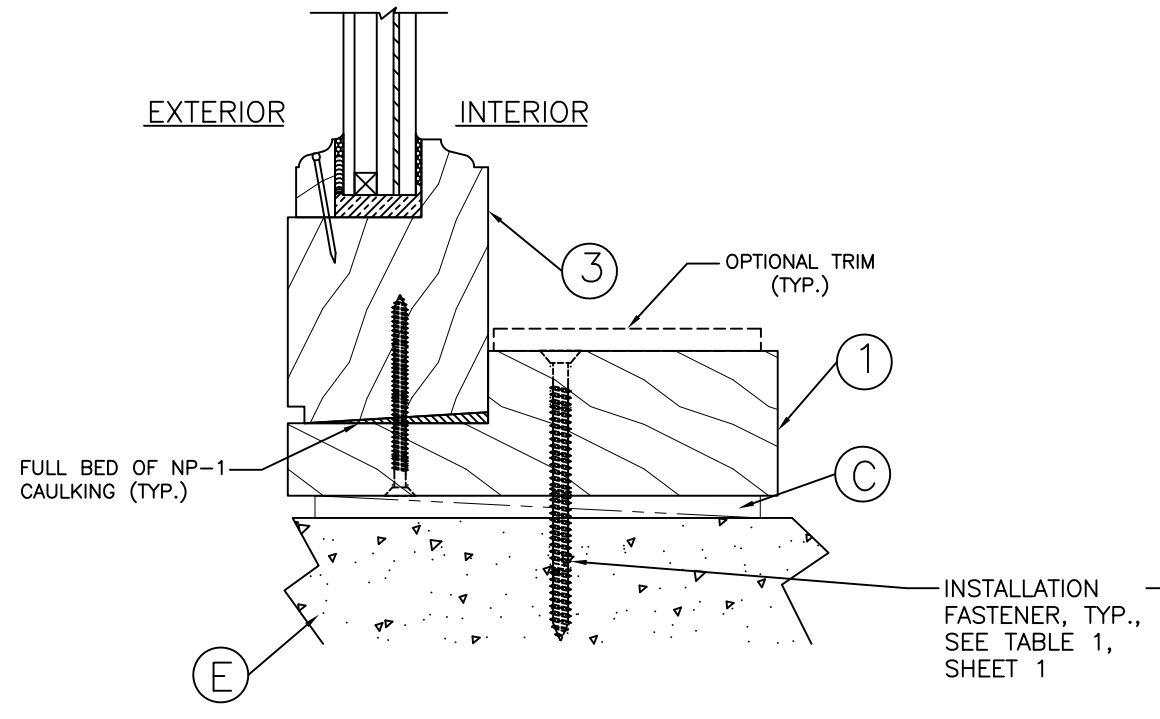

2 VERTICAL CROSS SECTION  
 3 Shown Direct To Masonry

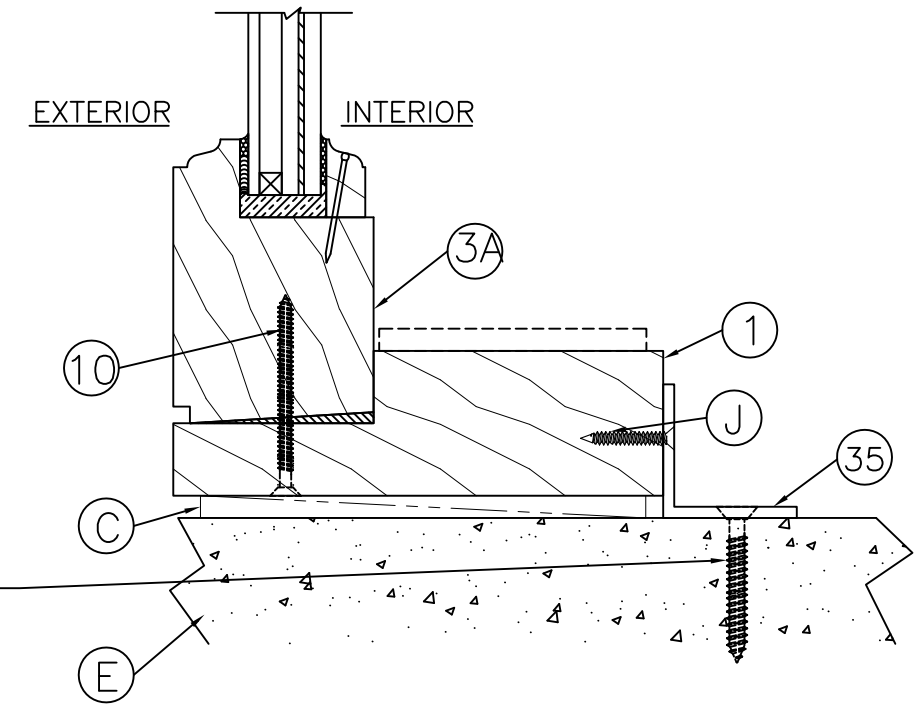

4 VERTICAL CROSS SECTION  
 3 Shown Direct To Masonry w/ Aluminum Sill Anchor

VERTICAL CROSS SECTIONS

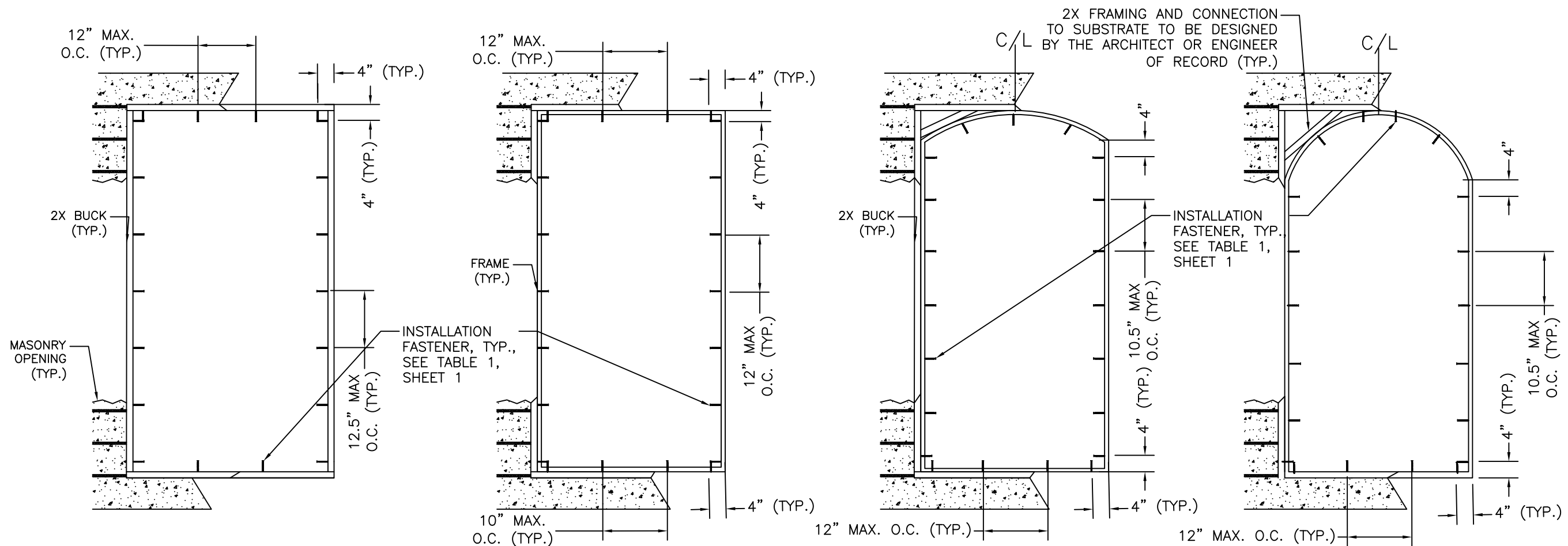

**FRAME ANCHORING**  
Masonry construction

**FRAME ANCHORING**  
Rectangular

**FRAME ANCHORING**  
Arch Top

**FRAME ANCHORING**  
Round Top

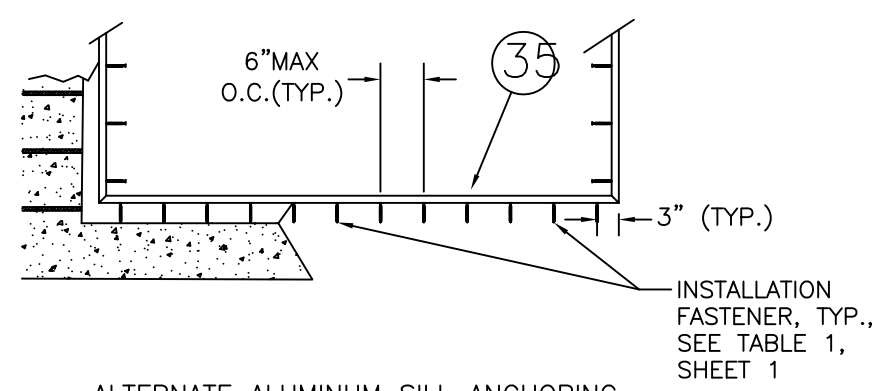

**ALTERNATE ALUMINUM SILL ANCHORING**

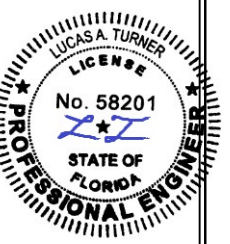
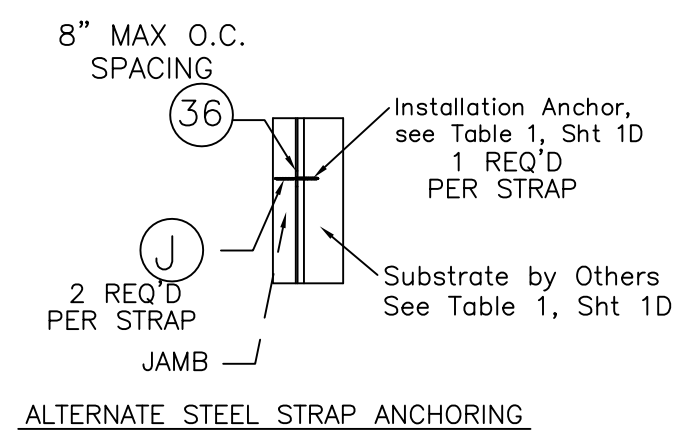
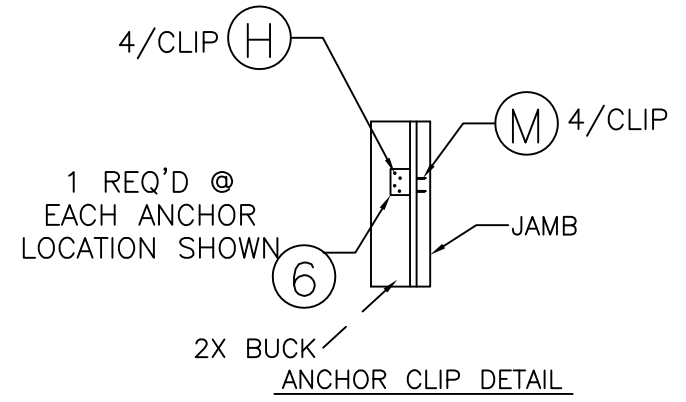

10/18/2023

TE&C  
LUCAS A. TURNER, P.E. FL PE 58201  
TURNER ENGINEERING & CONSULTING, INC.  
PH. 941-380-1574  
2428 OLD NATCHEZ TRACE TRAIL  
CAMDEN, TN 38320

OWW LLC  
3001 Tuxedo Ave., West Palm Beach, FL 33405  
Ph. 561-478-7233 Fax 561-478-7858

Product: FIXED CASEMENT WINDOW  
Date: 01-18-18  
Scale: None  
Drawn: JDS

BUCK & FRAME ANCHORING

Dwg: FCA-0  
FL34943.1

Sheet No.  
4D OF 5

BILL OF MATERIALS		
ITEM #	DESCRIPTION	MATERIAL
A	1X BUCK (SG>=0.55)	WOOD
B	2X BUCK (SG>=0.55)	WOOD
C	1/4" MAX.SHIM SPACE	-
E	MASONARY - 3,000 PSI MIN. CONCRETE CONFORMING TO ACI 301 OR HOLLOW BLOCK CONFORMING TO ASTM C90	CONCRETE
H	#8 X 1-1/2" PFH WOOD SCREW	STEEL
J	#10 X 1-1/2" PFH WOOD SCREW	STEEL
M	#8 X 3/4" PPH SMS	STEEL
1	FRAME	WOOD
2	FRAME	LVL
3	SASH (MOULDING TO INTERIOR)	WOOD
3	SASH (MOULDING TO WEATHER)	WOOD
4	GLAZING BEAD (7/8" I.G.)	WOOD
5	GLAZING BEAD (7/16" MONO.)	WOOD
6	ANCHOR BRACKET (SIMPSON STRONG-TIE A23Z)	STEEL
10	#10 X 2-1/2" FH WOOD SCREW	STEEL
35	ALUMINUM SILL ANCHOR	ALUM
36	STEEL ANCHOR STRAP	STEEL

NOTE: ALL WINDOW FRAME WOOD: MIN. SG=0.50 (MAHOGANY OR SIMILAR)

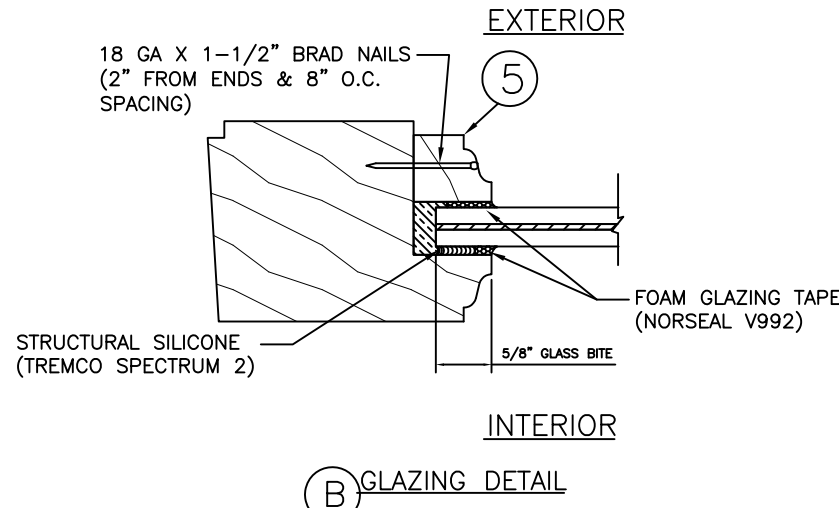
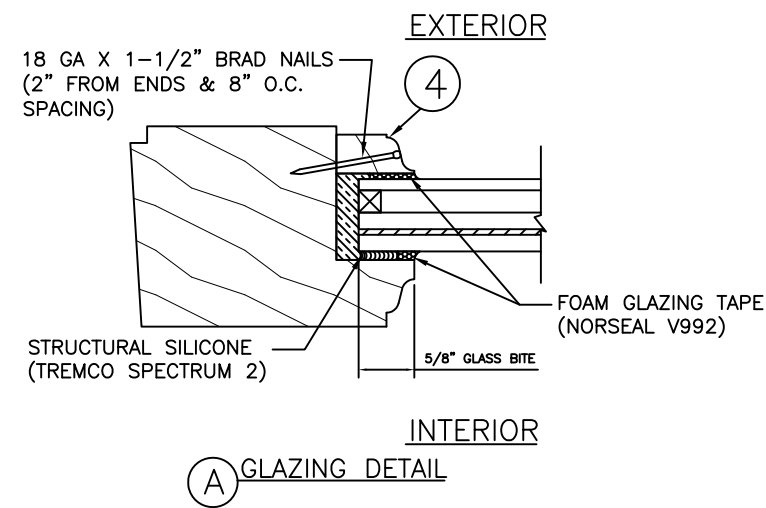
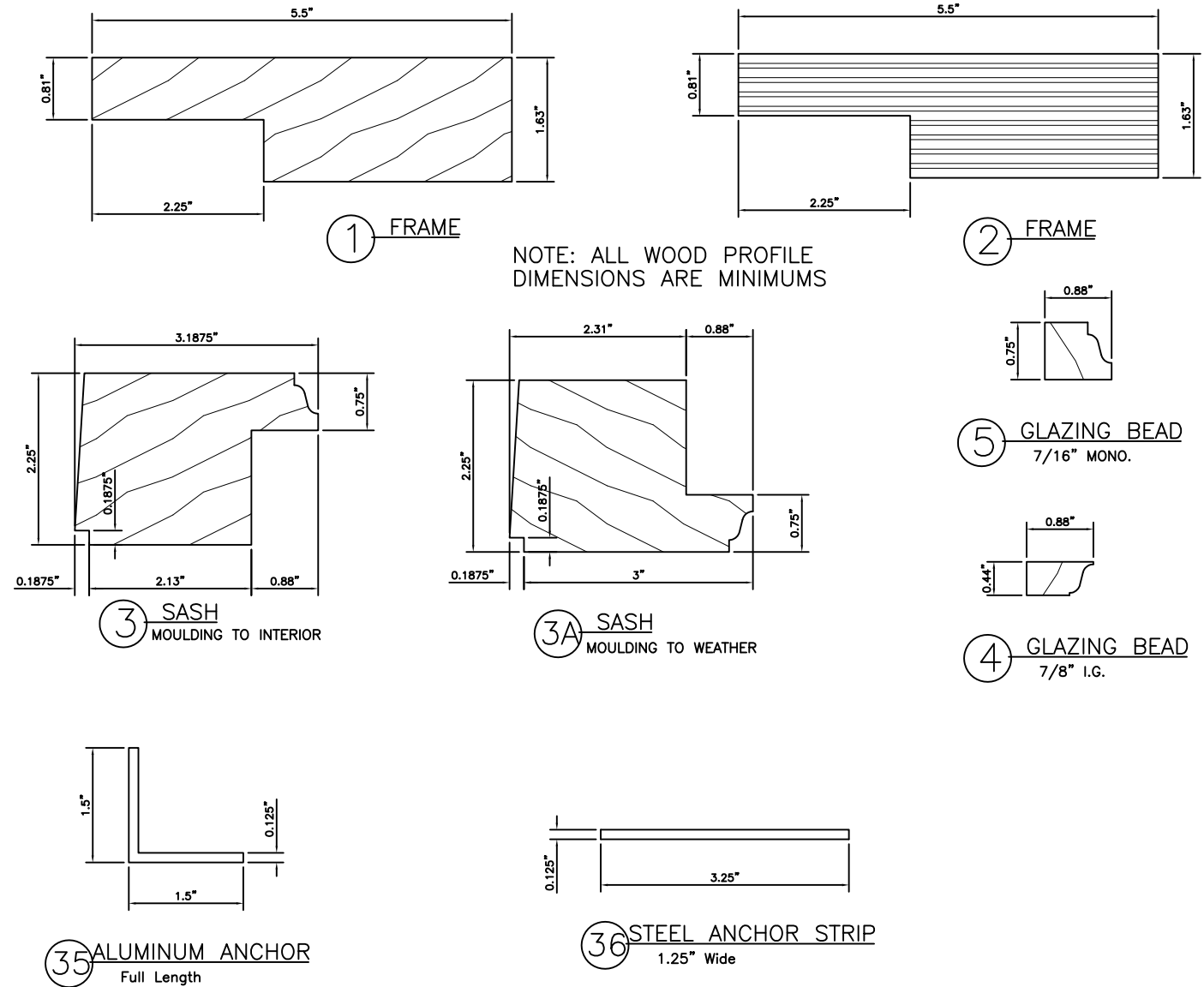

- GLASS TYPES AND STRUCTURE**
- A** 7/8" (NOM.) LAMINATED INSULATING GLASS  
1/8" EXTERIOR HEAT STRENGTHENED (IN HVHZ, ALLOWED ONLY WITHIN 30 FT OF GRADE) OR FULLY TEMPERED /  
1/4" AIR SPACE WITH ALUMINUM SPACER /  
3/16" ANNEALED  
.075" INTERLAYER: SAFLEX CP BY EASTMAN CHEMICAL COMPANY /  
3/16" ANNEALED
  - B** 7/16" (NOM.) STORM GLASS  
3/16" HEAT STRENGTHENED /  
.075" INTERLAYER: SAFLEX CP BY EASTMAN CHEMICAL COMPANY /  
3/16" HEAT STRENGTHENED

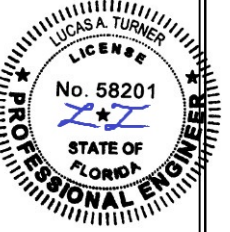

10/18/2023

TE&C  
LUCAS A. TURNER, P.E. FL PE 58201  
TURNER ENGINEERING & CONSULTING, INC.  
PH. 941-380-1574  
2428 OLD NATCHIEZ TRACE TRAIL  
CAMDEN, TN 38320

OWW LLC  
3001 Tuxedo Ave., West Palm Beach, FL 33405  
Ph. 561-478-7233 Fax 561-478-7858

Product: FIXED CASEMENT WINDOW  
Date: 01-18-18  
Scale: None  
Drawn: JDS

Dwg: FCA-0  
FL34943.1

Sheet No.  
5D OF 5